

创意材料公司 摄影/设计/印刷 0573-82112602

AAA Strut



ZHEJIANG LIANXIANG HARDWARE  
SCIENCE AND TECHNOLOGY CO.,LTD.

No. 100 Qinshan Road, Qinshan Street, Haiyan County, Zhejiang Province, China  
 TEL: +86-573-86112919 / 86169305  
 FAX: +86-573-86122733  
 E-mail: sales@cnlianxiang.com  
 http: //www.cnlianxiang.com



ZHEJIANG LIANXIANG HARDWARE  
SCIENCE AND TECHNOLOGY CO.,LTD.

**Fire Protection**  
**Plumbing System**  
**Electrical Installation**  
**Channel & Fittings**



www.cnlianxiang.com



# Let technology

build the **spirit**  
of products

High & new tech realizes high quality

First class equipment, first class operation level,

Makes first class products

Profession is reflected from details

## CONTENTS

<b>01</b>	About Us .....	01/08
<b>02</b>	Channels .....	09/11
<b>03</b>	Corner Angles .....	12
<b>04</b>	Channel Brackets .....	13/14
<b>05</b>	Connectings .....	15/27
<b>06</b>	General Fittings .....	28/31
<b>07</b>	Pipe Clamps .....	32/46
<b>08</b>	Hangers .....	47/52
<b>09</b>	Beam Clamps .....	53/54
<b>10</b>	Rollers & Wheel Trolley .....	55/56
<b>11</b>	Seismic Bracing .....	57/59
<b>12</b>	Technical Data .....	60/65
<b>13</b>	Testing Report .....	66/67
<b>14</b>	Project Case .....	68



## Corporate Profile

Zhejiang Lianxiang Hardware Science and Technology Co.,Ltd has been built for more than 20 years. We have been devoting ourselves in the products of construction, electricity, new energy, petrochemical, mechanical engineering and other industries. We are leading the global world gradually.

Meeting our customers' requirements and making them satisfied is our goal, which is realized by our factory's specialization.

We get various information from different industries, and then develop different kinds of brackets and pipe support products. Our patent products are combined with domestic project design, they can meet the world's latest requirements.

Our new support and hanging systems represent innovation and time-saving. We can provide you the best example of construction while you are pursuing for all regulations and certifications.

We make everything easy, helping you find the best installation solution that you need. Our products have different finish, like hot dip galvanizing, powder coating, zinc plated, etc. Our products are strictly tested. Many of them have got UL and FM approved, the innovation design makes the installation easier and quicker.

Besides our saving time and energy solutions, we also provide excellent technology supporting service in special environment of hanging fields.

The future market belongs to Lianxiang!

We are your most reliable brand!



# PRODUCTION EQUIPMENTS

If an enterprise wants to produce first-class product, it has to be equipped with first-class machines. with imported advanced equipment from foreign countries that produced in accordance with the international standards.



ZHEJIANG LIANXIANG  
HARDWARE SCIENCE  
AND TECHNOLOGY CO.,LTD.



Based on the new starting point,  
create a new situation!



# ZHEJIANG LIANXIANG HARDWARE SCIENCE AND TECHNOLOGY CO., LTD.

If you want to do some thing better,  
you must first grind your sword.



Our production team ——  
Hand in hand, in each day and night, we hand in hand diligently is fighting bravely for yours enterprise.  
By the specialty experience, we reduce the process period, promptly respond the customer's suggestion,  
meet the customer's need.

Among numerous and complicated process systems, we firmly carry out comprehensive quality management,  
and set up strict operation standard for each link and process, and cooperat the comprehensive testing  
system, which guarantees the smooth flow of every process.



# Company Culture



# Strength can talk



Inspection Center technology permeates each segment of the professional inspection center. Technology speaks for quality.



## CHANNELS

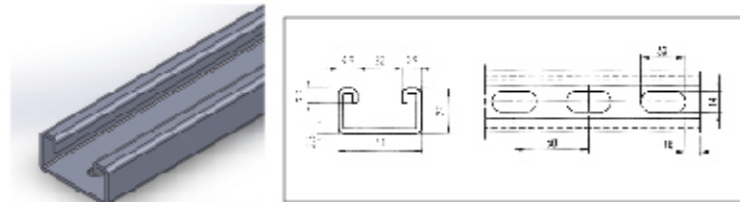

Item	Length(m)	Thickness(mm)
LX-21 Gal	3	2.0
LX-21 HDG	3	2.5
LX-21 Epoxy	3	2.5

### Features:

- 1."A" level stability
- 2."A" level strength
- 3."A" level shape

### Technical Reference:

#### × Material:

S235 JR according to DIN EN 10025  
S280 GD according to DIN EN 10147

#### × Finish:

Pre-galvanized / HDG / Epoxy

### MPA FIRE TEST REPORT

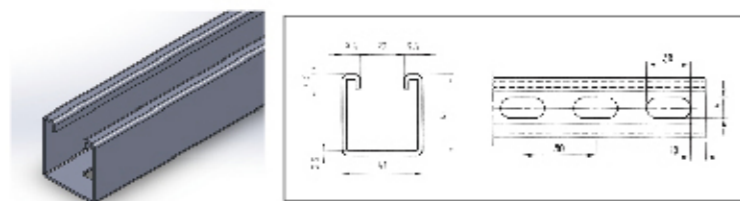

Item	Length(m)	Thickness(mm)
LX-41 Gal	3	2.0
LX-41 HDG	3	2.5
LX-41 Epoxy	3	2.5

### MPA FIRE TEST REPORT

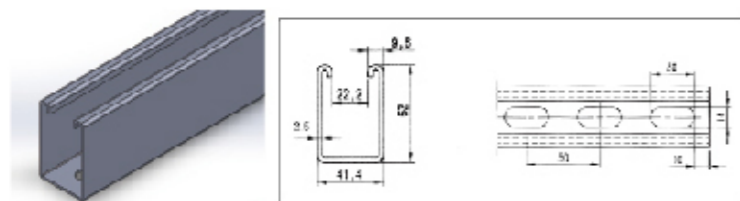

Item	Length(m)	Thickness(mm)
LX-62 Gal	3	2.0
LX-62 HDG	3	2.5
LX-62 Epoxy	3	2.5

## WELDED CHANNELS

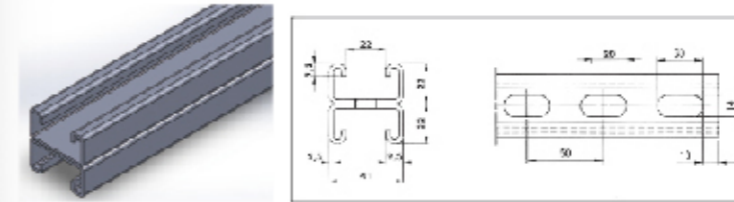

Item	Length(m)	Thickness(mm)
LX-21D Gal	3	2.0
LX-21D HDG	3	2.5
LX-21D Epoxy	3	2.5

### Features:

- 1."A" level stability
- 2."A" level strength
- 3."A" level shape

### Technical Reference:

#### × Material:

S235 JR according to DIN EN 10025  
S280 GD according to DIN EN 10147

#### × Finish:

Pre-galvanized / HDG / Epoxy

### MPA FIRE TEST REPORT

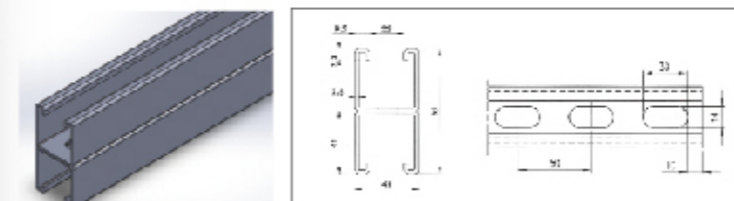

Item	Length(m)	Thickness(mm)
LX-41D Gal	3	2.0
LX-41D HDG	3	2.5
LX-41D Epoxy	3	2.5

### MPA FIRE TEST REPORT

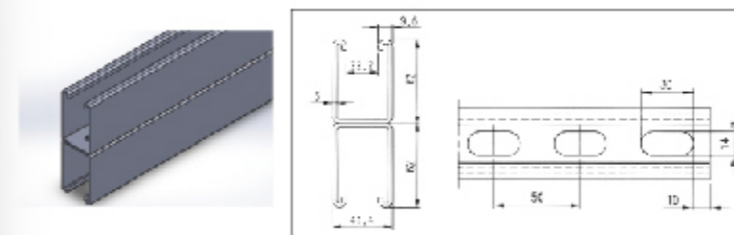

Item	Length(m)	Thickness(mm)
LX-62D Gal	3	2.0
LX-62D HDG	3	2.5
LX-62D Epoxy	3	2.5

## SPECIAL CHANNELS

We can produce special channels as per customer's requests.

※Material: Steel/Stainless steel

※Finish: ZP/HDG/Stainless Steel

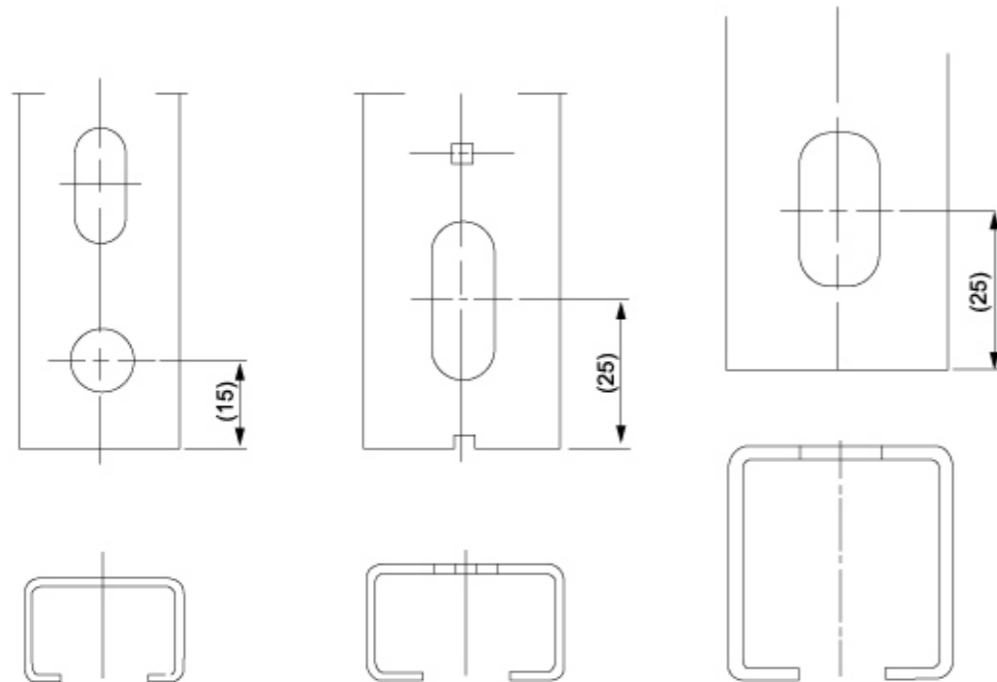

Item No.	Size	Thickness(mm)	Note
LXSC2010	20X10	0.8	-
LXSC2718	27X18	1.25	-
LXSC2730	27X30	1.5	-
LXSC3420	34X20	2.4	-
LXSC3535	35X35	2.0	-
LXSC3840	38X40	2.0	-

## CORNER ANGLES

They can be easily used in many pipe lines operations.

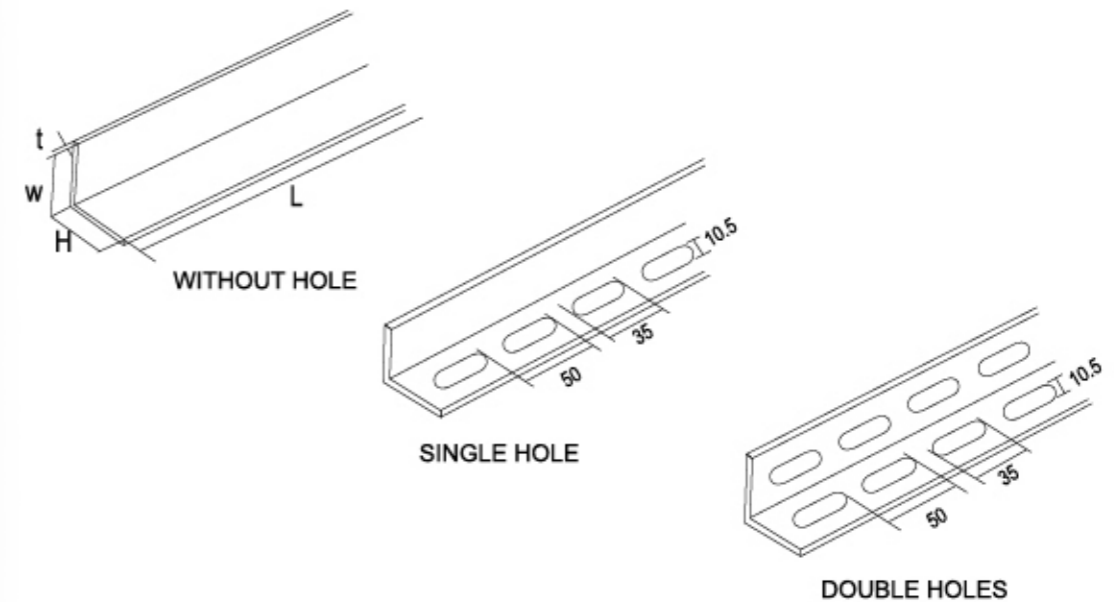

unit: kg

Item No.	Hole type	Size TxHxWxL	Min load in center					Max load in center				
			0.4	0.6	0.8	1.0	1.2	0.4	0.6	0.8	1.0	1.2
L340	WITHOUT HOLE	3X40X40X3000	176	119	76	63	45	300	215	145	125	90
L440		4X40X40X3000	226	156	108	83	60	385	280	205	165	120
L450		4X50X50X3000	347	239	174	133	110	590	430	330	265	220
L550		5X50X50X3000	424	300	213	163	130	720	540	405	325	260
LD340	SINGLE HOLE	3X40X40X3000	150	102	65	53	38	255	183	123	106	77
LD440		4X40X40X3000	193	132	92	70	51	327	238	174	140	102
LD450		4X50X50X3000	295	203	148	113	94	502	366	281	225	187
LD550		5X50X50X3000	360	255	181	138	111	612	459	344	276	221
LDD340	DOUBLE HOLES	3X40X40X3000	132	90	57	47	34	225	161	109	94	68
LDD440		4X40X40X3000	170	117	81	62	45	289	210	154	124	90
LDD450		4X50X50X3000	260	179	130	99	83	443	323	248	199	165
LDD550		5X50X50X3000	318	225	160	122	98	540	405	304	244	195

※Material: Steel ※Surface: ZP/HDG

## CHANNEL BRACKETS

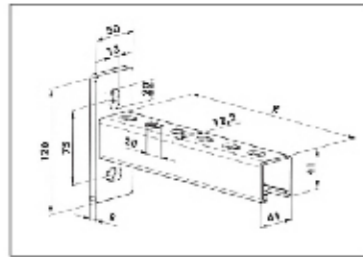
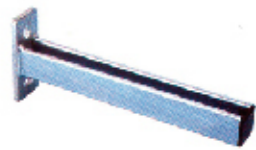

### Features:

1. Widely being used to fix pipes on the wall.
2. Channel fittings, end caps could be fit to.
3. Suggest to chose stainless steel or HDG when being used outside.

### Technical Reference:

- ✘ **Material:** S235 JR according to DIN EN 10025
- ✘ **Finish:** Pre-galvanized / HDG / Epoxy

Channel Bracket			Loading					Weight	Packing
Item No.	Model Length	Available Length	q	F <sub>1</sub>	F <sub>1</sub>	F <sub>2</sub> F <sub>2</sub>	F <sub>3</sub> F <sub>3</sub> F <sub>3</sub>		
			KN						
	in mm	in mm	in KN/m	in KN/m	in KN/m	in KN/m	in KN/m	Kg/pc	pcs/box
LXCB01	300	323	8.76	2.76	1.38	1.38	0.92	1.15	10
LXCB02	450	463	4.20	1.91	0.96	0.96	0.64	1.5	10
LXCB03	600	638	2.19	1.38	0.69	0.69	0.46	1.92	10
LXCB04	750	778	1.47	1.13	0.56	0.56	0.38	2.5	10

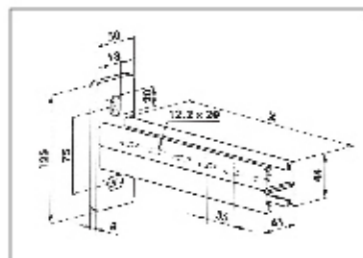

### Features:

1. Widely being used to fix pipes on the wall.
2. Channel fittings, end caps could be fit to.
3. Suggest to chose stainless steel or HDG when being used outside.

### Technical Reference:

- ✘ **Material:** S235 JR according to DIN EN 10025
- ✘ **Finish:** Pre-galvanized / HDG / Epoxy

Channel Bracket			Loading					Weight	Packing
Item No.	Model Length	Available Length	q	F <sub>1</sub>	F <sub>1</sub>	F <sub>2</sub> F <sub>2</sub>	F <sub>3</sub> F <sub>3</sub> F <sub>3</sub>		
			KN						
	in mm	in mm	in KN/m	in KN/m	in KN/m	in KN/m	in KN/m	Kg/pc	pcs/box
LXCB05	300	315	9.86	3.11	1.55	1.55	1.04	1.46	10
LXCB06	450	455	4.73	2.15	1.08	1.08	0.72	1.95	10
LXCB07	600	630	2.47	1.55	0.78	0.78	0.52	2.55	10

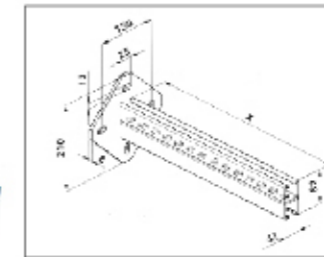

### Features:

1. Widely being used to fix pipes on the wall.
2. Channel fittings, end caps could be fit to.
3. Suggest to chose stainless steel or HDG when being used outside.

### Technical Reference:

- ✘ **Material:** S235 JR according to DIN EN 10025
- ✘ **Finish:** Pre-galvanized / HDG / Epoxy

Channel Bracket			Loading					Weight	Packing
Item No.	Model Length	Available Length	q	F <sub>1</sub>	F <sub>1</sub>	F <sub>2</sub> F <sub>2</sub>	F <sub>3</sub> F <sub>3</sub> F <sub>3</sub>		
			KN						
	in mm	in mm	in KN/m	in KN/m	in KN/m	in KN/m	in KN/m	Kg/pc	pc/box
LXCB08	750	778	4.76	3.66	1.83	1.83	0.46	5.4	1
LXCB09	1000	1023	2.74	2.78	1.39	1.39	0.35	6.7	1

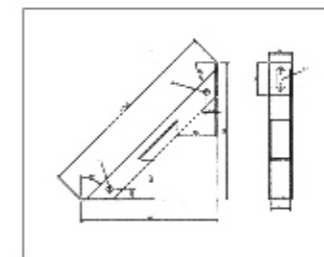
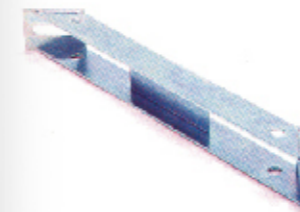

### Features:

1. Apply to wall cylinder cantilever installation.
2. When install pipe on the brackets, especially heat distribution pipeline, in order to prevent the stent system failure, have to pass a brace against axial stress.
3. The design is concise and practical, convenient and quick installation.

### Technical Reference:

- ✘ **Material:** S235 JR according to DIN EN 10025
- ✘ **Finish:** Pre-galvanized / HDG / Epoxy

Item	F(N)	Length(mm)	Width(mm)	Weight(kg)	Packing
Inclined Strut	4500	450	50	0.95	10pcs/box

# CONNECTINGS

## Plane Combinations

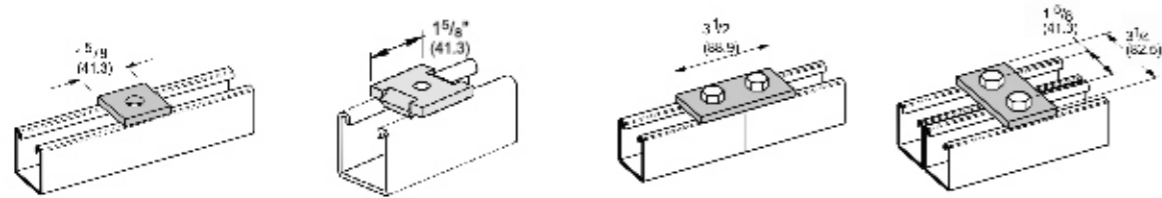

L1001

L1002

L1003

L1004

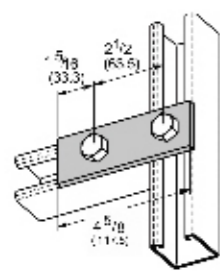

L1005

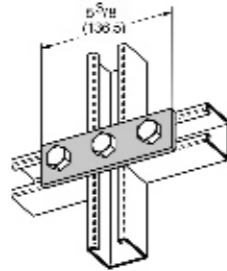

L1006

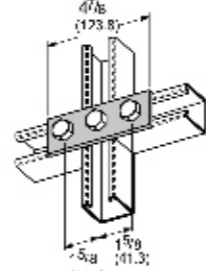

L1007

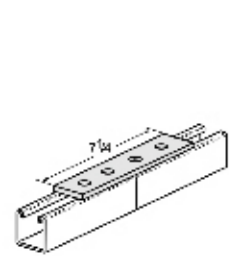

L1008

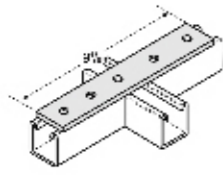

L1009

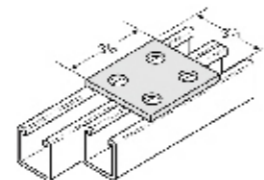

L1010

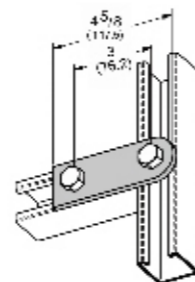

L1011

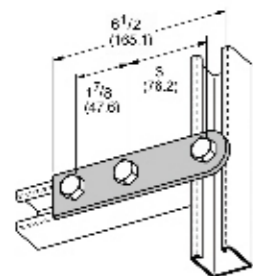

L1012

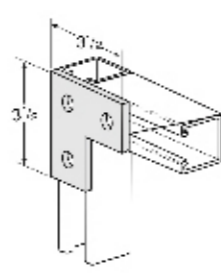

L1013

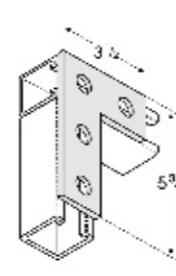

L1014

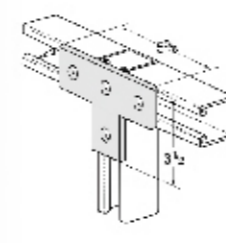

L1015

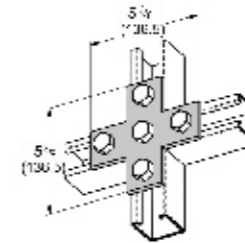

L1016

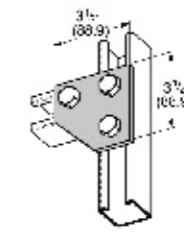

L1017

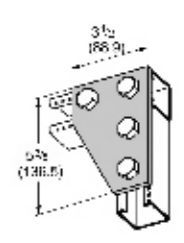

L1018

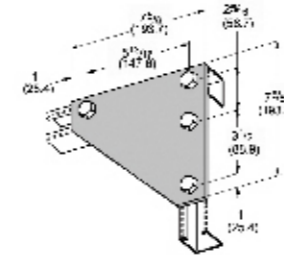

L1019

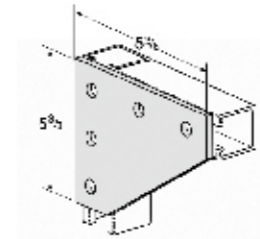

L1020

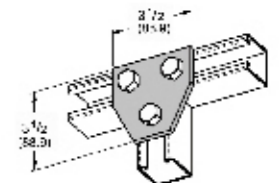

L1021

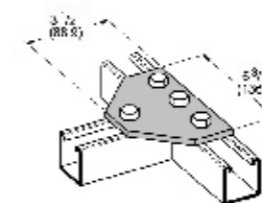

L1022

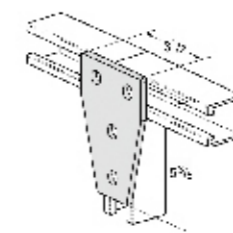

L1023

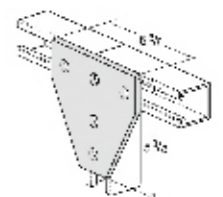

L1024

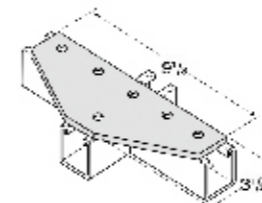

L1025

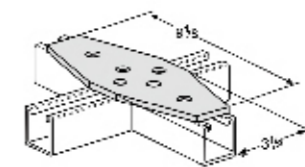

L1026

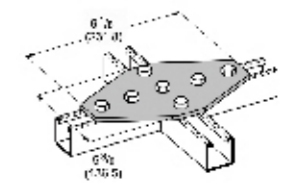

L1027

# CONNECTINGS

## 90° Combinations

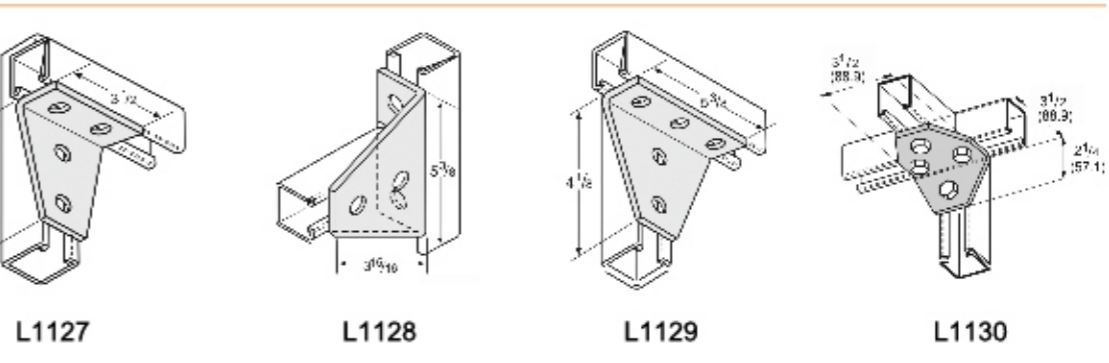
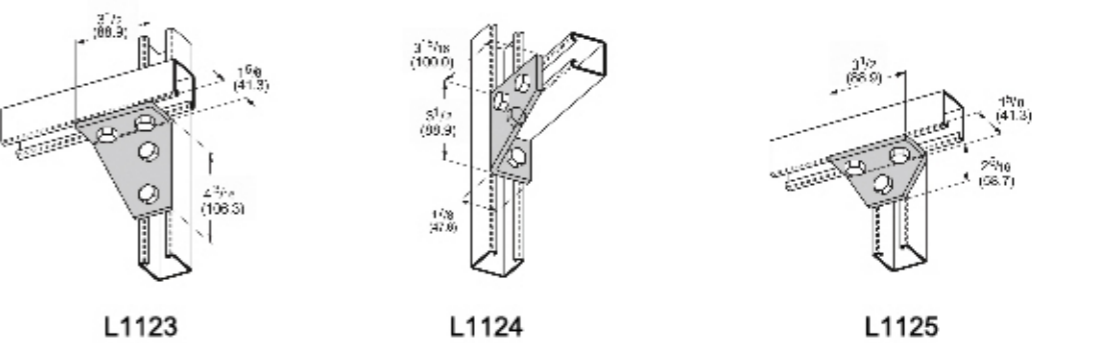
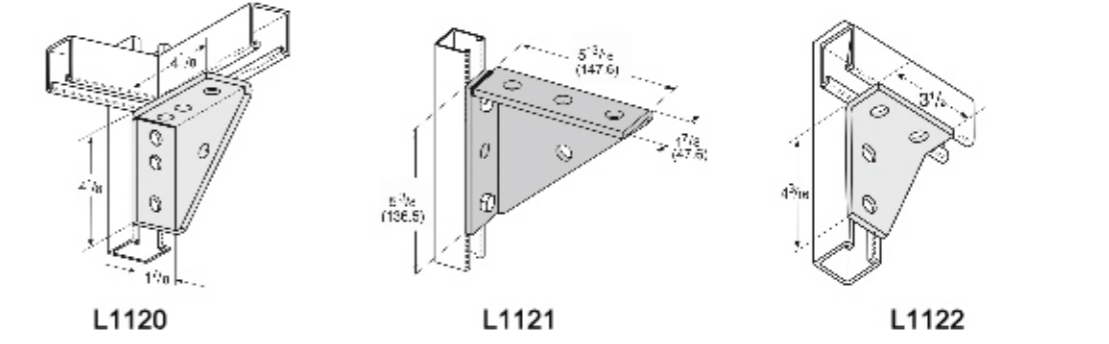
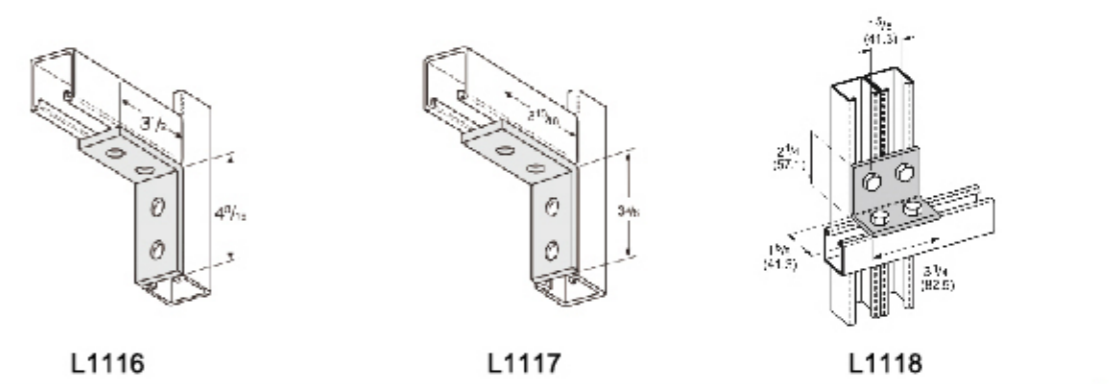
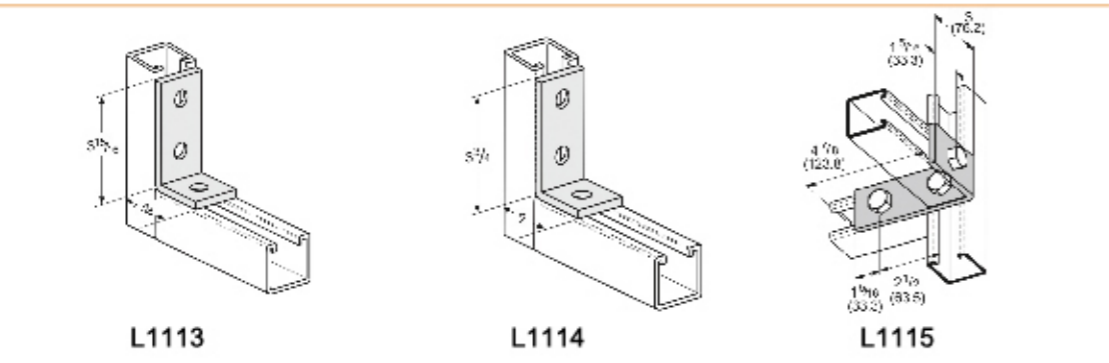
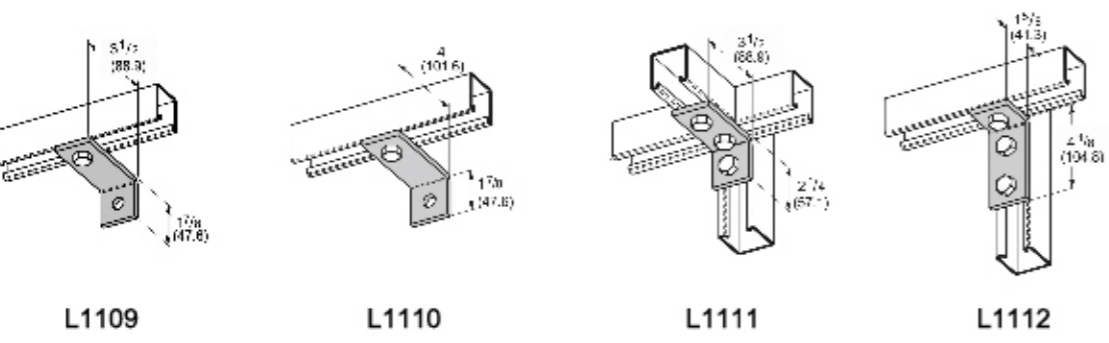
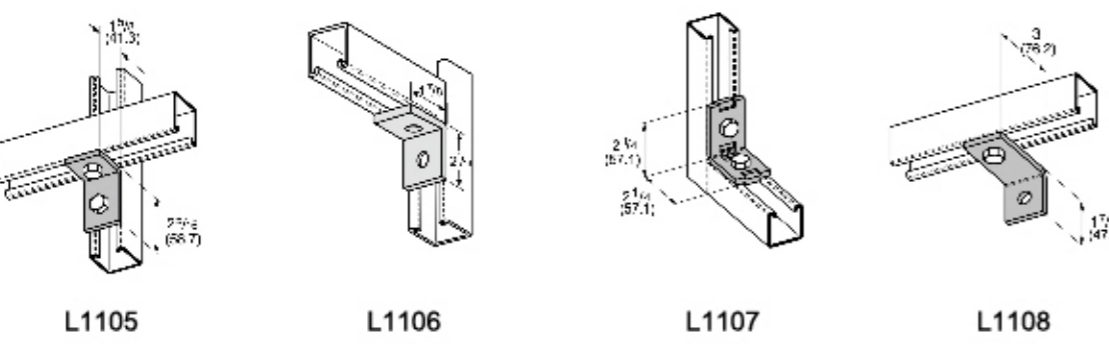
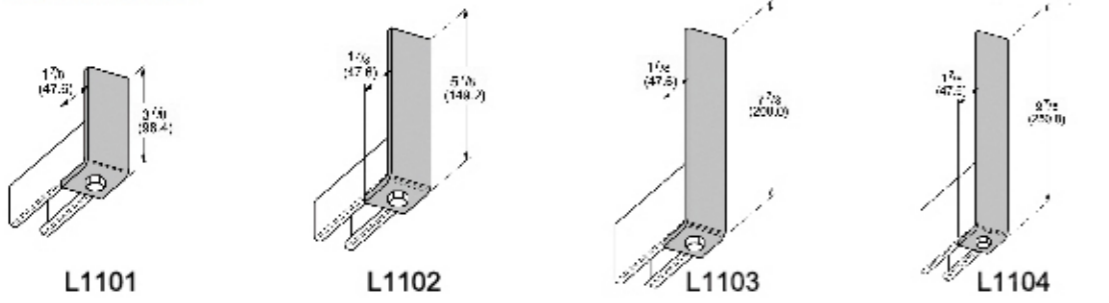

## CONNECTINGS

### 90° Combinations

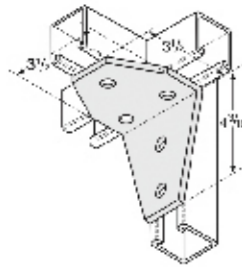

L1131

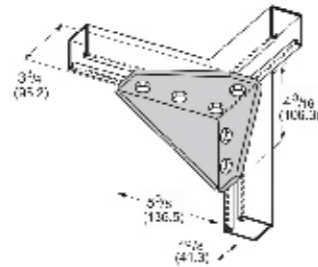

L1132

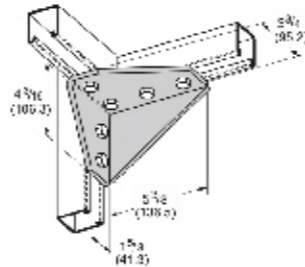

L1133

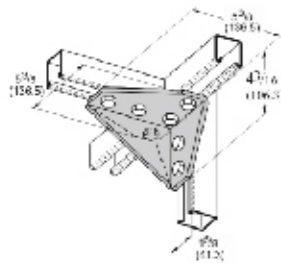

L1134

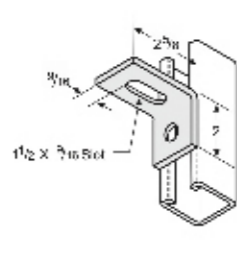

L1135

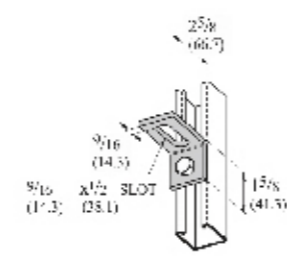

L1136

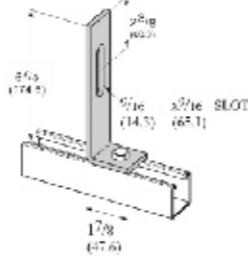

L1137

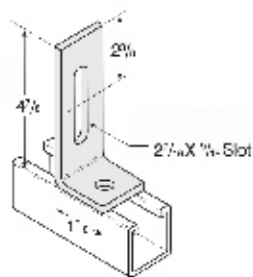

L1138

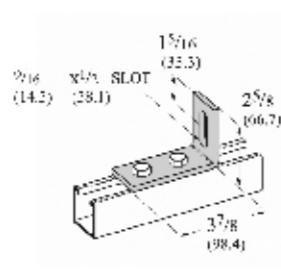

L1139

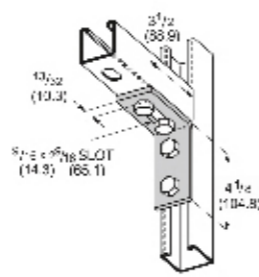

L1140

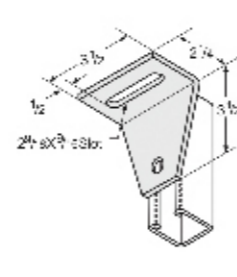

L1141

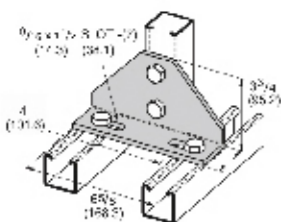

L1142

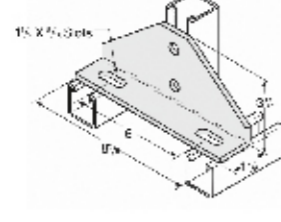

L1143

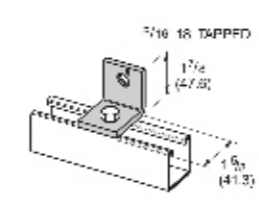

L1144

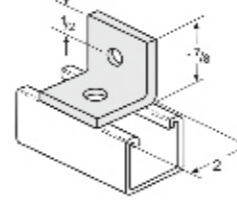

L1145

### Z-Type Combinations

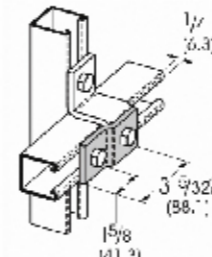

L1201

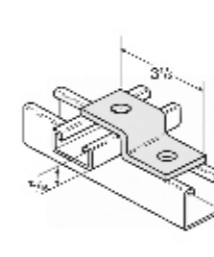

L1202

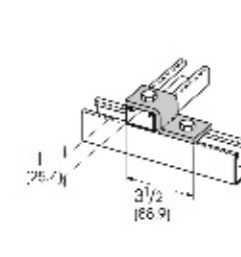

L1203

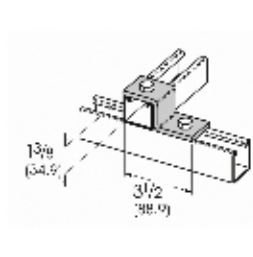

L1204

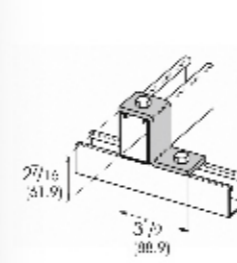

L1205

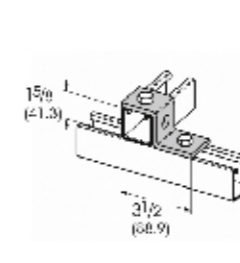

L1206

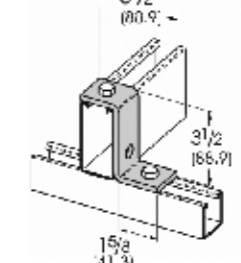

L1207

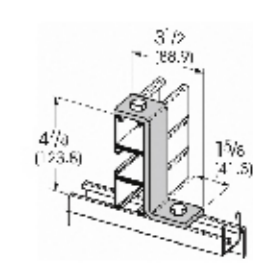

L1208

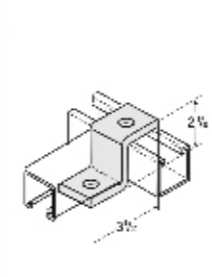

L1209

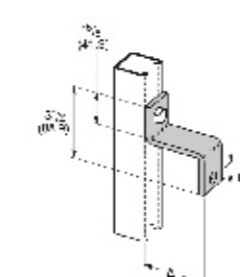

L1210

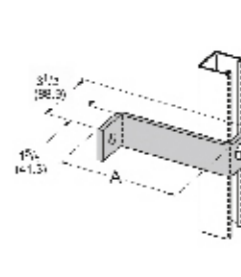

L1211

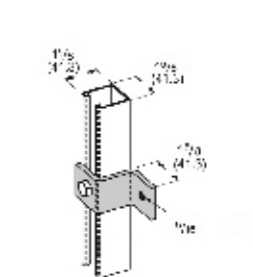

L1212

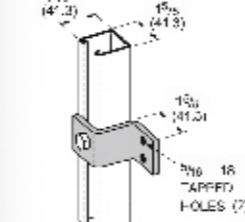

L1213

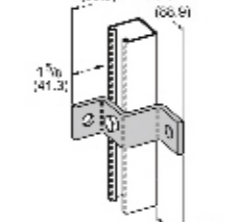

L1214

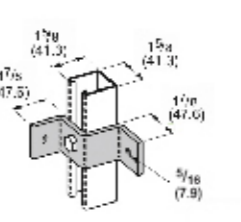

L1215

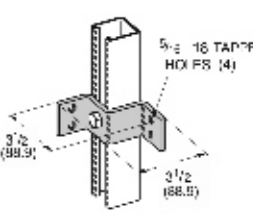

L1216

## CONNECTINGS

### U-Type Combinations

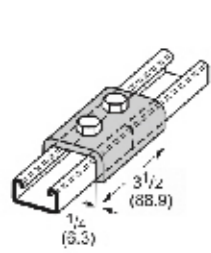

L1301

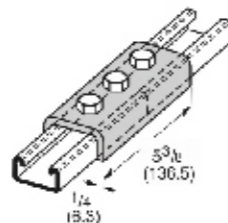

L1302

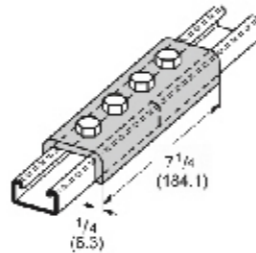

L1303

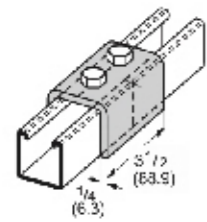

L1304

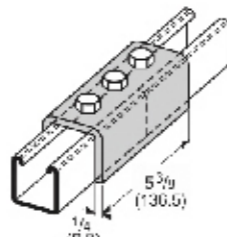

L1305

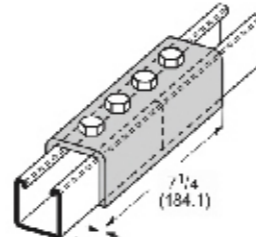

L1306

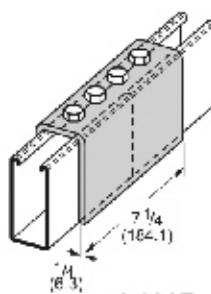

L1307

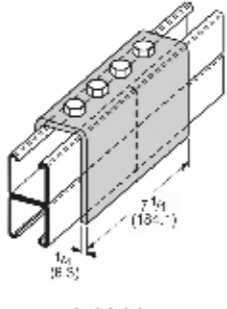

L1308

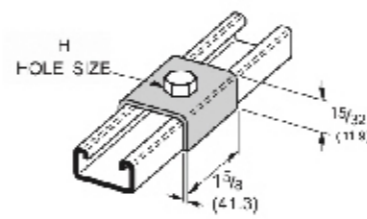

L1309

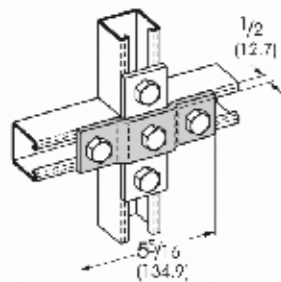

L1310

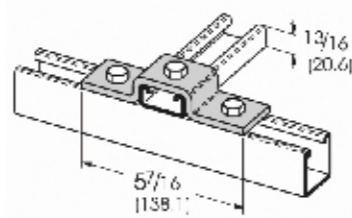

L1311

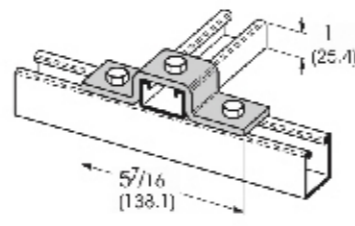

L1312

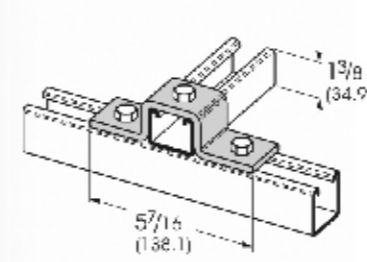

L1313

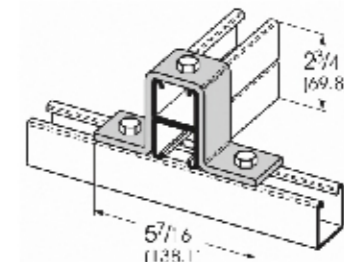

L1314

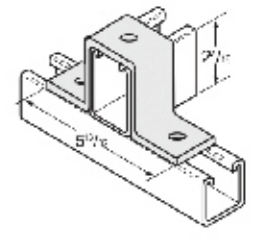

L1315

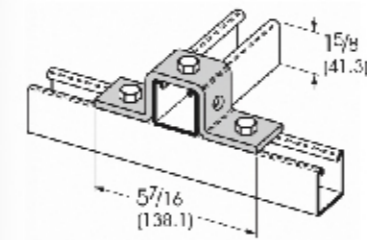

L1316

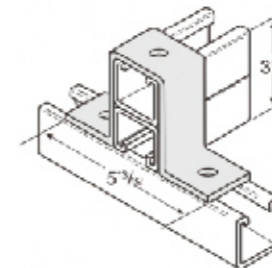

L1317

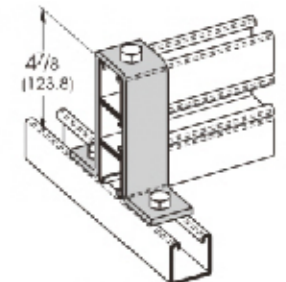

L1318

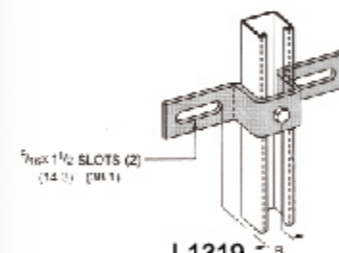

L1319

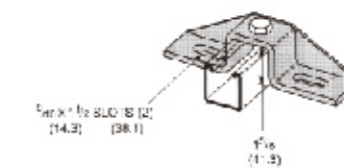

L1320

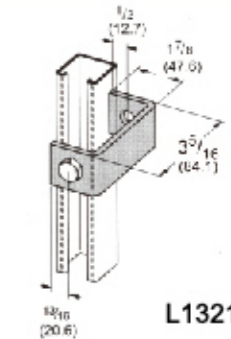

L1321

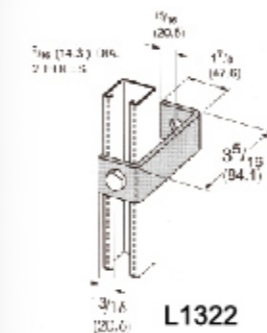

L1322

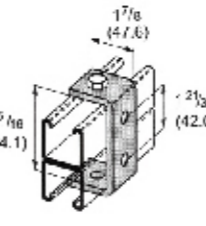

L1323

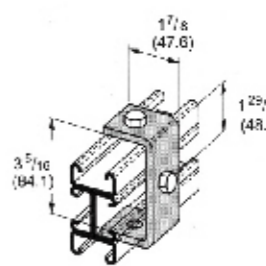

L1324

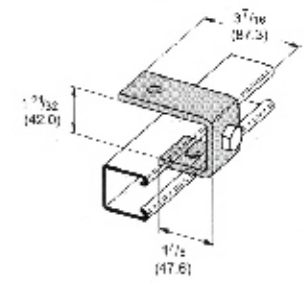

L1325

## CONNECTINGS

### Wing Type Combinations

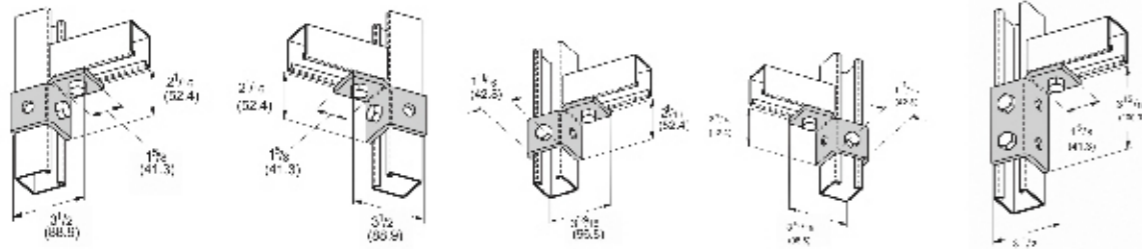

L1501      L1502      L1503      L1504      L1505

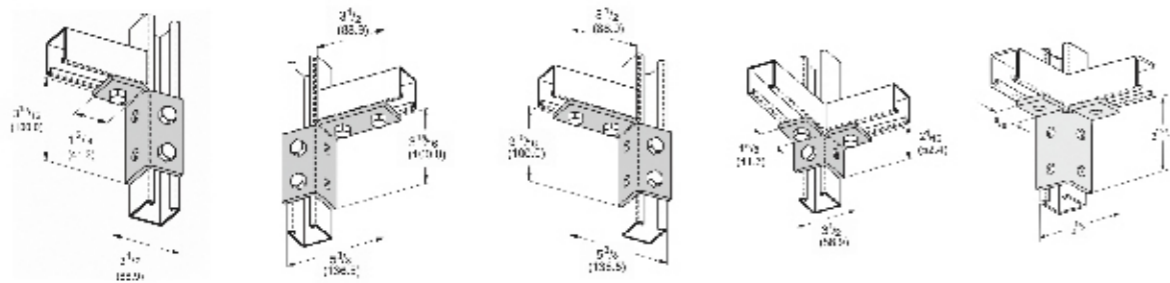

L1506      L1507      L1508      L1509      L1510

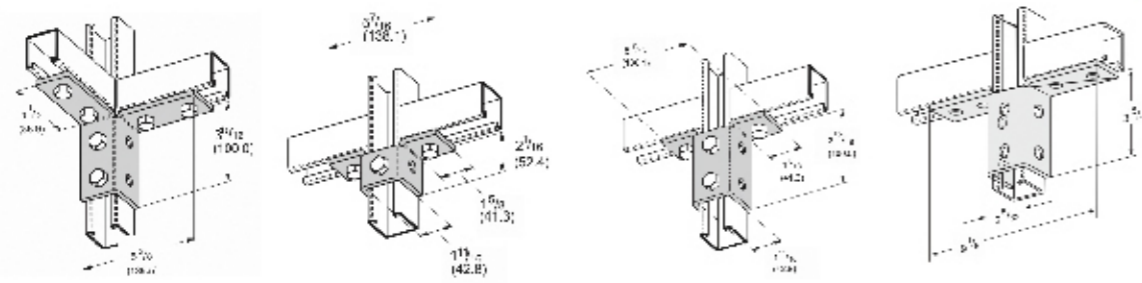

L1511      L1512      L1513      L1514

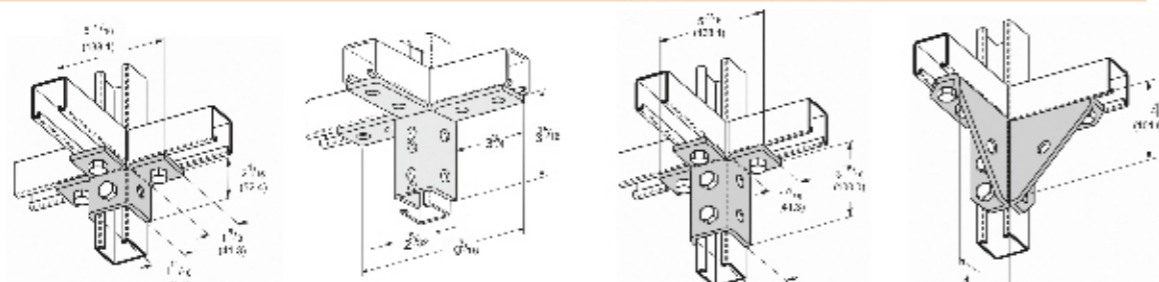

L1515      L1516      L1517      L1518

### Post Bases

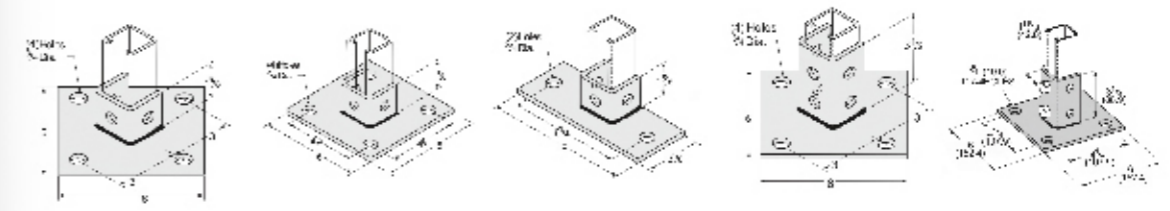

L1601      L1602      L1603      L1604      L1605

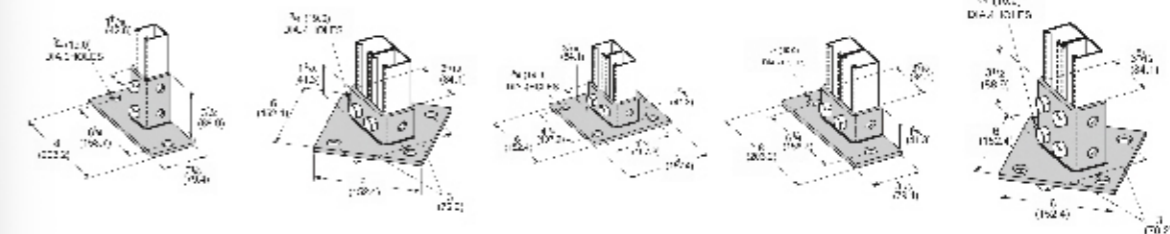

L1606      L1607      L1608      L1609      L1610

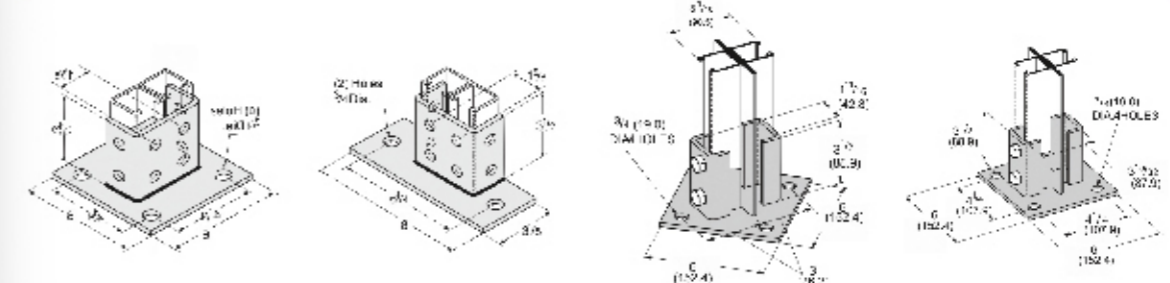

L1611      L1612      L1613      L1614

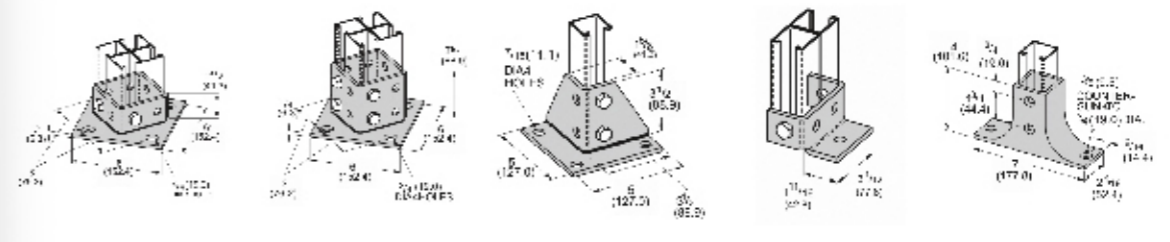

L1615      L1616      L1617      L1618      L1619

## CONNECTINGS

### Other Combinations

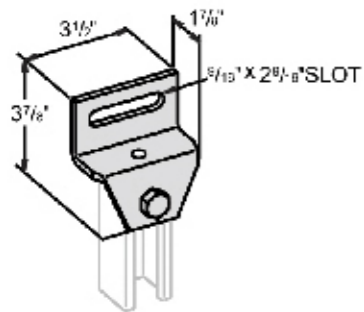

L1401

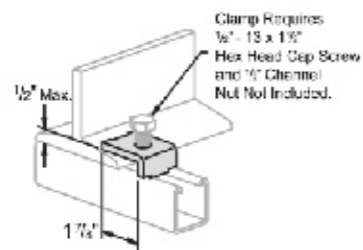

L1402

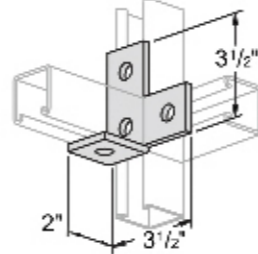

L1403

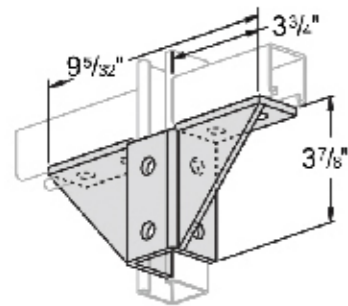

L1404

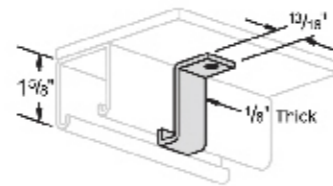

L1406

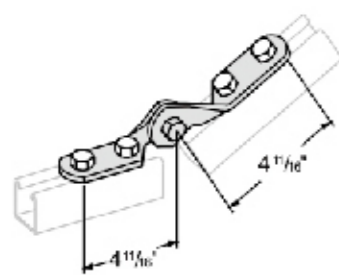

L1407

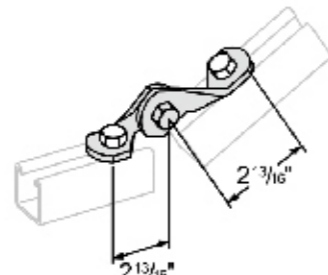

L1408

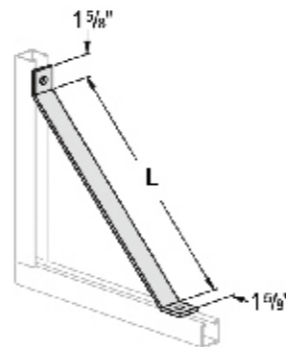

L1409

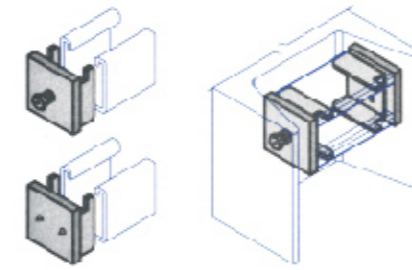

L1410

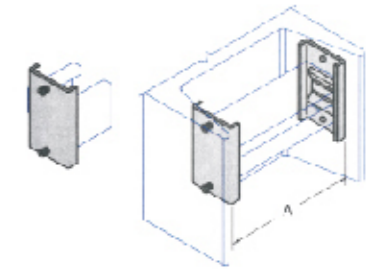

L1411

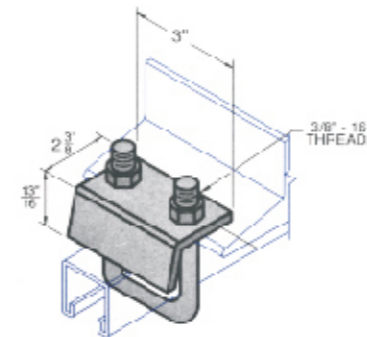

L1412

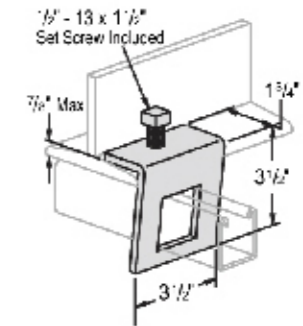

L1405

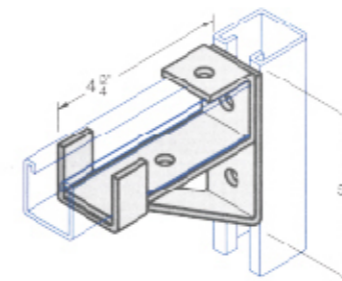

L1413

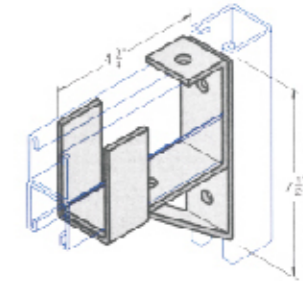

L1414

## CHANNEL END CAPS

Item No.	Suitable Channel	Using Type
HEC001	LX-21	Insert
HEC002	LX-41	Insert
HEC003	LX-41	Output

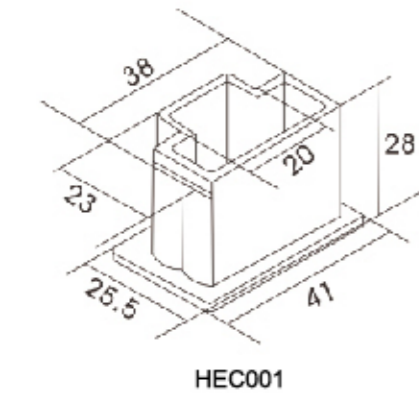

HEC001

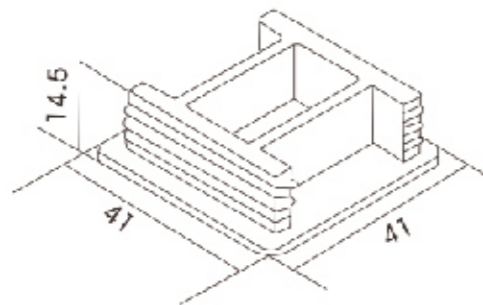
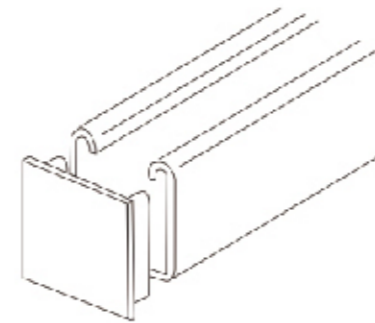

HEC002

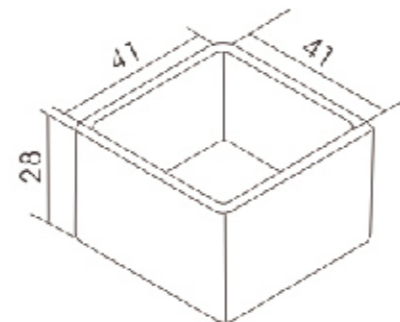

HEC003

## CHANNEL WASHERS

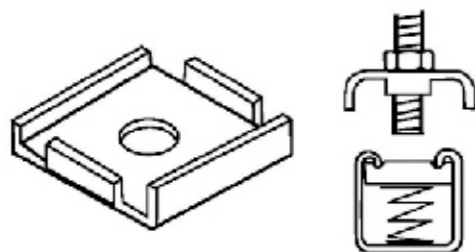

Item No.	Rod Size	Hole Size	Thickness (mm)
WH20	M6,W1/4	6.5	2
WH25	M8,W5/16	8.5	2
WH30	M10,W3/8	10.5	2
WH40	M12,W1/2	13	2

## CHANNEL NUTS

It is more convenient to use channel nuts when they are added with springs. They can be easily fixed in any channels.

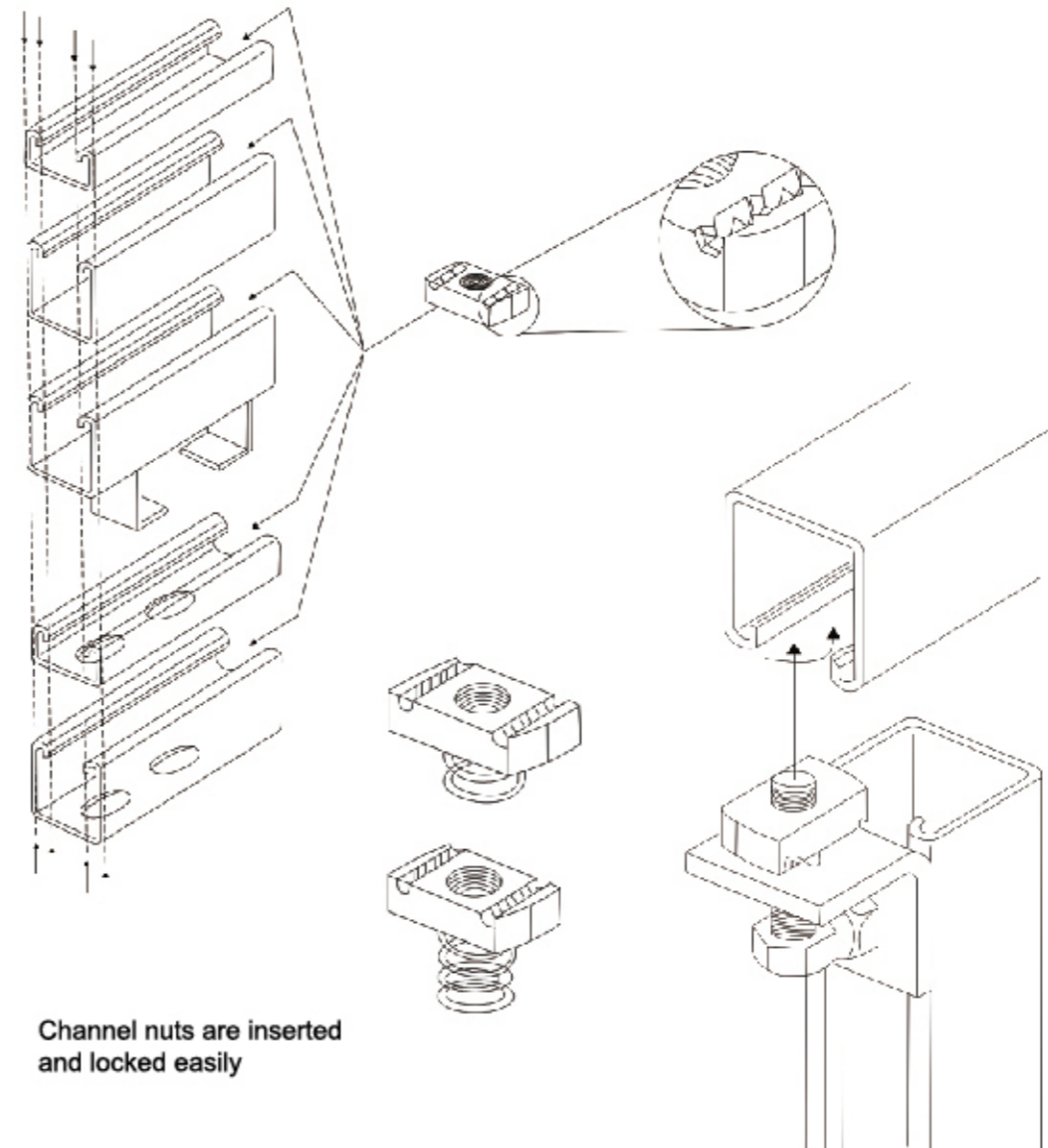

Channel nuts are inserted and locked easily

## CHANNEL NUTS

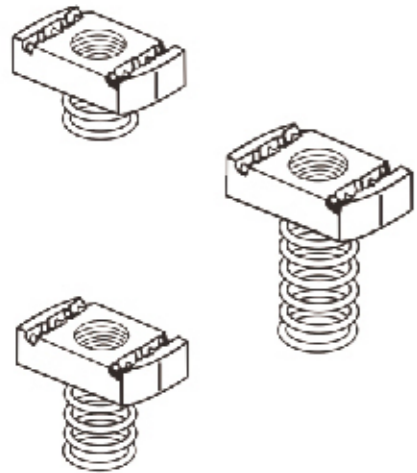

Size	Standard Channel		Low Foot Channel		Strengthen Channel	
	Code	Weight	Code	Weight	Code	Weight
M6X6	HN06	29	HN06L	29	LN06H	31
M8x6	HN08	28	HN08L	27	LN08H	29.5
M10X9	HN10	40	HN10L	39	LN10H	42
M12X12	HN12	46	HN12L	44	LN12H	48
M16X12	HN16	74	HN16L	72	LN16H	76
W1/4X1/4	HN20	28	HN20L	31	LN20H	31
W5/16X1/4	HN25	28	HN25L	29.5	LN25H	28.9
W3/8X3/8	HN30	40	HN30L	42	LN30H	42
W1/2X1/2	HN40	46	HN40L	48	LN40H	48
W5/8X1/2	HN50	74	HN50L	76	LN50H	76

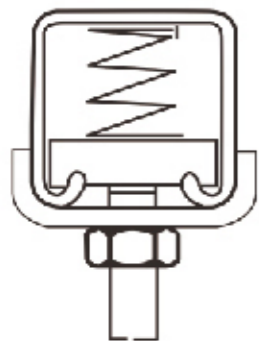
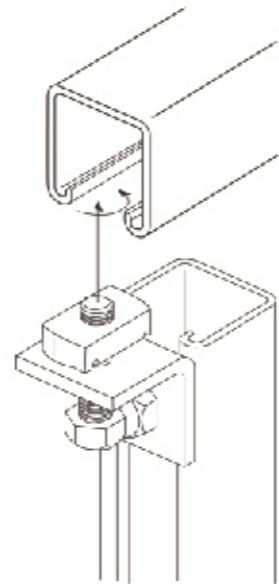
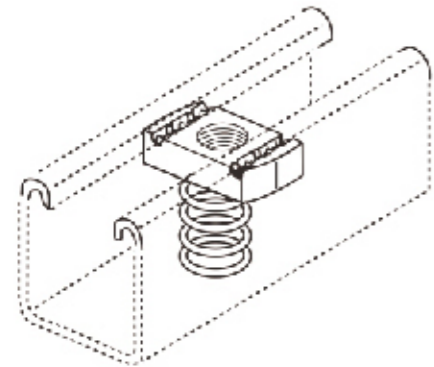

Channel nuts and channel washers make your fastening perfect. Brackets can match other fittings of our factory.

## THREADED FASTENERS



### Lock Washers

Size	Wt./100 Pcs
1/4"	0.3
3/8"	0.7
1/2"	1.5

Material: Carbon Steel / Stainless Steel

### Flat Washers

Size	Wt./100 Pcs
1/4"	0.7
3/8"	1.5
1/2"	3.5

Material: Carbon Steel / Stainless Steel

### Hex Nuts

Size	Wt./100 Pcs
1/4"	0.6
5/16"	1.2
3/8"	1.6
1/2"	4.8

Material: Carbon Steel / Stainless Steel

### Square Nuts

Size	Wt./100 Pcs
1/4"	0.9
5/16"	1.6
3/8"	2.7
1/2"	5.8

Material: Carbon Steel / Stainless Steel

### Hex Head Cap Screws

Diameter	Length	Wt./100 Pcs.	Diameter	Length	Wt./100 Pcs.
1/4"	1/2"	1.0	3/8"	2 1/4"	8.5
1/4"	3/4"	1.3	1/2"	1"	9.1
1/4"	1"	1.7	1/2"	1 1/4"	10.0
3/8"	3/4"	4.0	1/2"	1 1/2"	11.6
3/8"	1"	4.5	1/2"	1 3/4"	13.2
3/8"	1 1/4"	5.3	1/2"	2"	14.7
3/8"	1 1/2"	6.1	1/2"	2 1/4"	16.0
3/8"	2"	7.6	1/2"	2 1/2"	17.5

Material: Carbon Steel / Stainless Steel

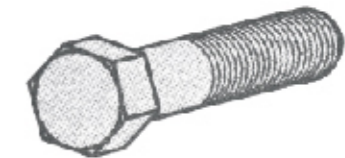

### All-Thread Rod

Diameter	Thd.	Wt./100 Ft.
1/4"	20	12
3/8"	16	30
1/2"	13	54
5/8"	11	85
3/4"	10	125

Length: 6', 10' & 12'  
Material: Carbon Steel / Stainless Steel

### Rod Couplers

Hole Size	Thd.	"A" Length	Wt./100 Pcs.
1/4"	20	7/8"	2
3/8"	16	1 3/4"	11
1/2"	13	1 3/4"	11
5/8"	11	2 1/8"	16
3/4"	10	2 1/4"	28

Material: Carbon Steel / Stainless Steel

## FIXING METHODS

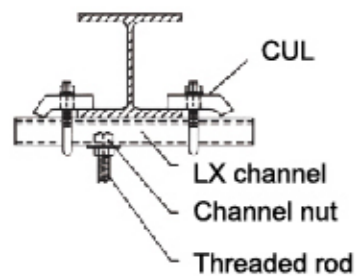
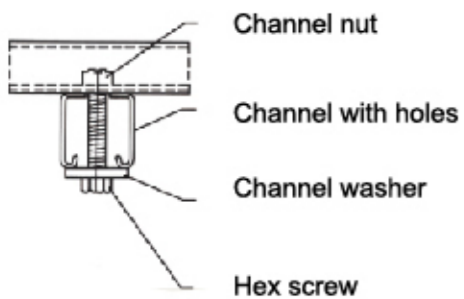
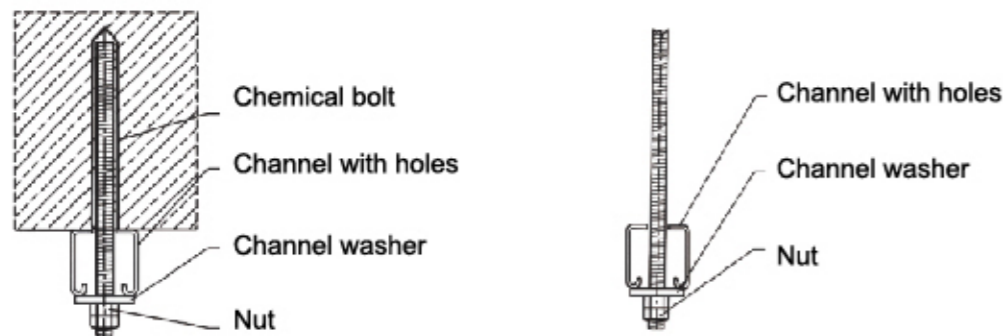
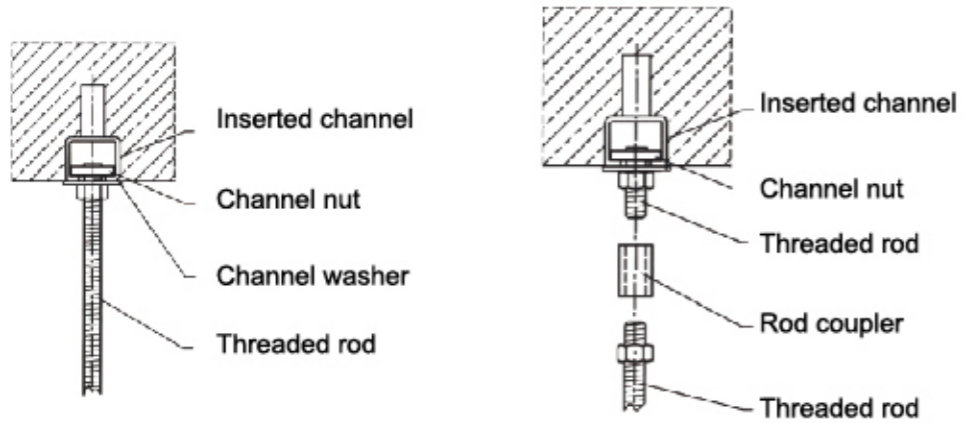

Different functions have different fixing methods. Please have a look at this page of fixing methods for your reference to play the role of products most effectively.

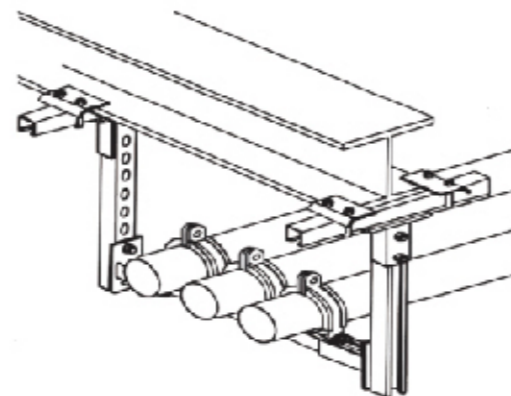

## STANDARD U BOLTS

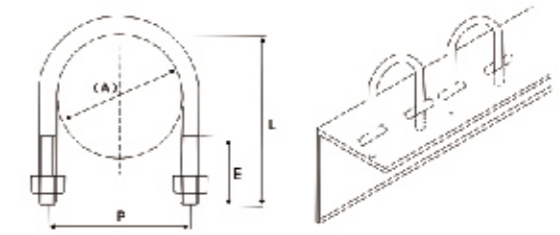

Size		Pipe OD	Diameter M6			Diameter M8			Diameter M10			Diameter M12		
DIN	BSW		P	L	E	P	L	E	P	L	E	P	L	E
15A	1/2	21.7	30	36	18	31	42	24	34	45	30			
20A	3/4	27.2	34	42	18	37	48	24	40	51	30			
25A	1	34.0	41	49	25	44	54	25	46	59	30			
32	1-1/4	42.7	51	57	25	52	62	30	56	68	30			
40A	1-1/2	48.6	57	68	25	59	67	30	62	74	30			
50A	2	60.5	70	80	30	71	80	30	74	85	30			
65A	2-1/2	76.3				86	101	35	88	107	35			
80A	3	89.1				99	110	35	101	117	35			
100A	4	114.3				124	135	35	126	145	35			
125A	5	139.8							152	175	40	154	175	45
150A	6	165.2							180	200	40	182	200	45
200A	8	216.3										232	252	45

## PIPE SHOES

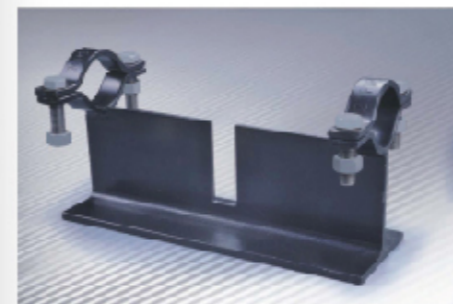

Item No.	Size	Pipe OD	Max. Load	
			650°F	750°F
LXPS-02	2"	60.4	1040	930
LXPS-03	3"	89	1040	930
LXPS-04	4"	114.5	1040	930
LXPS-05	6"	168.5	1615	1440

## U-TYPE CLAMPS

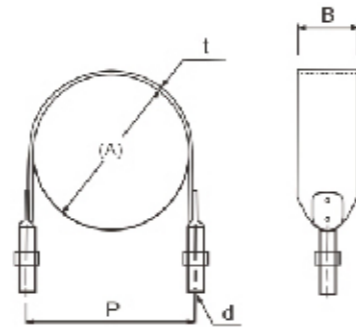

Item No.	Pipe	Pipe OD (mm)	txB	P	D
LXUC020	20A	27.2	2.0X25	38	M10
LXUC025	25A	34.0	2.0X25	45	M10
LXUC032	32A	42.7	2.0X25	54	M10
LXUC040	40A	48.6	2.0X25	60	M10
LXUC050	50A	60.5	2.0X25	69	M10
LXUC065	65A	76.3	2.0X25	84	M10
LXUC080	80A	89.1	2.0X32	95	M10
LXUC100	100A	114.3	2.0X32	120	M10
LXUC125	125A	139.8	2.0X32	154	M12
LXUC150	150A	165.2	2.0X32	175	M12
LXUC200	200A	216.3	2.0X32	226	M12

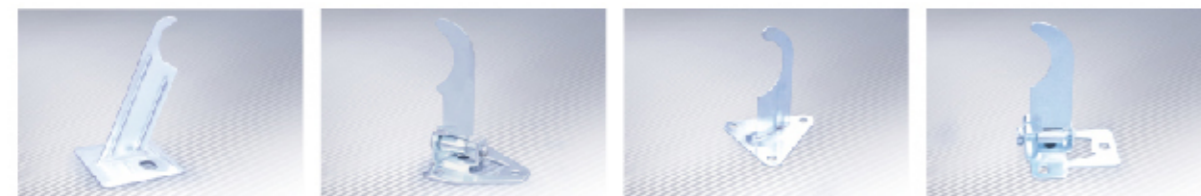

LXS-201

LXS-202

LXS-203

LXS-206

## CUSHION CLAMPS



LX Colourful Cushion Clamps have service temperatures of -65°F to 340°F (-53°C to 170°C)



LX Standard Cushion Clamps have an operating range of -50°F to 275°F (-45°C to 135°C)

LX Colourful Cushion Clamps				
O.D. Tube size	Dimensions (inches)			
	A	B	C	D
1/4"	0.25	0.62	0.27	0.98
3/8"	0.37	0.82	0.33	1.13
1/2"	0.50	0.94	0.40	1.34
5/8"	0.62	1.06	0.46	1.54
3/4"	0.75	1.20	0.52	1.68
7/8"	0.87	1.31	0.58	1.82
1"	1.00	1.44	0.65	1.95
1 1/8"	1.12	1.57	0.70	2.08
1 1/4"	1.25	1.70	0.77	2.21
1 3/8"	1.37	1.82	0.83	2.34
1 1/2"	1.50	1.95	0.90	2.47
1 5/8"	1.62	2.07	0.96	2.60
1 3/4"	1.75	2.20	1.02	2.73
1 7/8"	1.87	2.32	1.09	2.86
2"	2.00	2.45	1.15	3.04
2 1/8"	2.12	2.57	1.27	3.23
2 1/4"	2.25	2.82	1.41	3.67
2 3/8"	2.37	2.82	1.41	3.67
2 1/2"	2.50	2.94	1.46	3.79
2 5/8"	2.62	3.07	1.53	3.92
2 7/8"	2.87	3.32	1.66	4.17
3"	3.00	3.57	1.78	4.42
3 1/8"	3.12	3.57	1.78	4.42
3 1/4"	3.50	3.95	1.97	4.79
4"	4.00	4.45	2.28	5.11
4 1/8"	4.12	4.57	2.34	5.54
4 1/2"	4.50	4.95	2.53	5.92

LX Standard Cushion Clamps				
O.D. Tube size	Dimensions (inches)			
	A	B	C	D
1/4"	0.25	0.62	0.27	0.98
3/8"	0.37	0.82	0.33	1.13
1/2"	0.50	0.94	0.40	1.34
5/8"	0.62	1.06	0.46	1.54
3/4"	0.75	1.20	0.52	1.68
7/8"	0.87	1.31	0.58	1.82
1"	1.00	1.44	0.65	1.95
1 1/8"	1.12	1.57	0.70	2.08
1 1/4"	1.25	1.70	0.77	2.21
1 3/8"	1.37	1.82	0.83	2.34
1 1/2"	1.50	1.95	0.90	2.47
1 5/8"	1.62	2.07	0.96	2.60
1 3/4"	1.75	2.20	1.02	2.73
1 7/8"	1.87	2.32	1.09	2.86
2"	2.00	2.45	1.15	3.04
2 1/8"	2.12	2.57	1.27	3.23
2 1/4"	2.25	2.82	1.41	3.67
2 3/8"	2.37	2.82	1.41	3.67
2 1/2"	2.50	2.94	1.46	3.79
2 5/8"	2.62	3.07	1.53	3.92
2 7/8"	2.87	3.32	1.66	4.17
3"	3.00	3.57	1.78	4.42
3 1/8"	3.12	3.57	1.78	4.42
3 1/4"	3.50	3.95	1.97	4.79
4"	4.00	4.45	2.28	5.11
4 1/8"	4.12	4.57	2.34	5.54
4 1/2"	4.50	4.95	2.53	5.92

LX Colourful Cushion Clamps				
Pipe size	Dimensions (inches)			
	A	B	C	D
1/2"	0.840	1.29	0.58	1.82
3/4"	1.050	1.57	0.70	2.08
1"	1.315	1.76	0.81	2.34
1 1/2"	1.900	2.32	1.09	2.86
2"	2.375	2.82	1.41	3.67
2 1/2"	2.875	3.32	1.66	4.17
3"	3.500	3.95	1.97	4.79
3 1/2"	4.000	4.45	2.28	5.11
4"	4.500	4.95	2.53	5.92

LX Standard Cushion Clamps				
Pipe size	Dimensions (inches)			
	A	B	C	D
1/2"	0.840	1.29	0.58	1.82
3/4"	1.050	1.57	0.70	2.08
1"	1.315	1.76	0.81	2.34
1 1/2"	1.900	2.32	1.09	2.86
2"	2.375	2.82	1.41	3.67
2 1/2"	2.875	3.32	1.66	4.17
3"	3.500	3.95	1.97	4.79
3 1/2"	4.000	4.45	2.28	5.11
4"	4.500	4.95	2.53	5.92

Walk in the forefront of the times and Lianxiang for your sake

## PIPE CLAMPS

### EMT Clamps

※Finish: EG / Epoxy

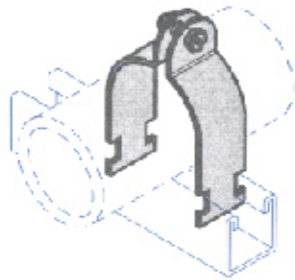

Nom. Comb. Size	O.D. Size	Steel Ga.	Pcs/Box
3/8"	0.577	16	100
1/2"	0.706	16	100
3/4"	0.922	16	100
1"	1.163	14	100
1 1/4"	1.510	14	100
1 1/2"	1.740	12	50
2"	2.197	12	50

### Universal Clamps

※Finish: EG / Epoxy

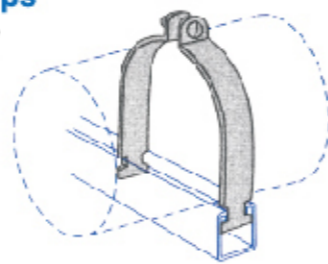

Nom. Size for E.M.T Rigid Copper Clamps	O.D. Range Min./Max.	Pcs/Box
3/8"	0.557 to 0.675	100
1/2"	0.706 to 0.840	100
3/4"	0.922 to 1.050	100
1"	1.163 to 1.315	100
1 1/4"	1.510 to 1.660	50
1 1/2"	1.740 to 1.900	50
2"	2.197 to 2.375	50

### Rigid Conduit Clamps

※Finish: EG / Epoxy

Pipe Size	O.D. Size	Steel Ga.	Pcs/Box
3/8"	0.675	16	100
1/2"	0.840	16	100
3/4"	1.050	14	100
1"	1.315	14	100
1 1/4"	1.660	14	50
1 1/2"	1.900	12	50
2"	2.375	12	50
2 1/2"	2.875	12	50
3"	3.500	12	50
3 1/2"	4.000	11	25
4"	4.500	11	25
5"	5.563	11	20
6"	6.625	10	20
8"	8.625	10	Bulk
10"	10.75	10	Bulk

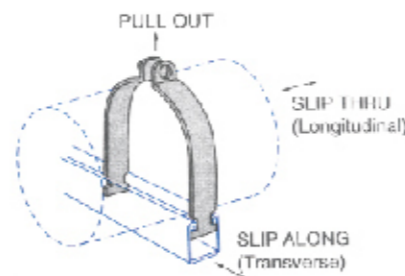

Nominal Pipe Size	Design Load*		
	Slip Thru(lbs)	Slip Along(lbs)	Pull out(lbs)
1/2"	213	77	907
3/4"	142	169	992
1"	131	174	806
1 1/4"	354	150	1,160
1 1/2"	335	336	1,564
2"	405	506	1,572
2 1/2"	287	548	1,610
3"	496	452	1,317
3 1/2"	434	531	1,490
4"	518	576	1,505
5"	411	567	1,313
6"	406	563	1,531
8"	580	664	2,018

### Tubig Clamps

※Finish: EG / Epoxy

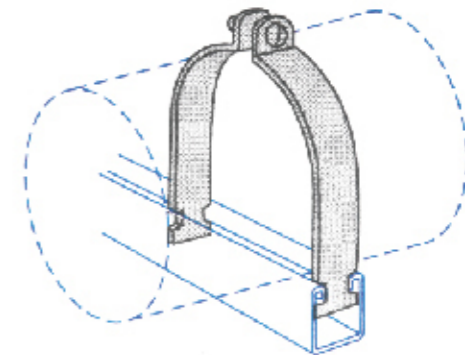

O.D. Size	Tube Size	Steel Ga.	Pcs/Box
1/4"	1/8"	16	100
3/8"	1/4"	16	100
1/2"	3/8"	16	100
5/8"	1/2"	16	100
3/4"	5/8"	16	100
7/8"	3/4"	16	100
1"	7/8"	14	100
1 1/8"	1"	14	100
1 1/4"	1 1/8"	14	100
1 3/8"	1 1/4"	14	100
1 1/2"	1 3/8"	14	100
1 5/8"	1 1/2"	14	100
1 3/4"	1 5/8"	12	50
1 7/8"	1 3/4"	12	50
2"	1 7/8"	12	50
2 1/8"	2"	12	50
2 1/4"	2 1/8"	12	50
2 3/8"	2 1/4"	12	50
2 1/2"	2 3/8"	12	50
2 5/8"	2 1/2"	12	50
2 3/4"	2 5/8"	12	50
2 7/8"	2 3/4"	12	50
3"	2 7/8"	12	50
3 1/8"	3"	12	25
3 1/4"	3 1/8"	12	25
3 3/8"	3 1/4"	12	25
3 1/2"	3 3/8"	12	25
3 5/8"	3 1/2"	11	25
3 3/4"	3 5/8"	11	25
3 7/8"	3 3/4"	11	25

O.D. Size	Tube Size	Steel Ga.	Pcs/Box
4"	3 7/8"	11	25
4 1/8"	4"	11	25
4 1/4"	4 1/8"	11	25
4 3/8"	4 1/4"	11	25
4 1/2"	4 3/8"	11	25
4 5/8"	4 1/2"	11	25
4 3/4"	4 5/8"	11	25
4 7/8"	4 3/4"	11	25
5"	4 7/8"	11	25
5 1/8"	5"	11	25
5 1/4"	5 1/8"	11	25
5 3/8"	5 1/4"	11	25
5 1/2"	5 3/8"	11	25
5 5/8"	5 1/2"	10	25
5 3/4"	5 5/8"	10	25
5 7/8"	5 3/4"	10	25
6"	5 7/8"	10	25
6 1/8"	6"	10	25
6 1/4"	6 1/8"	10	25
6 3/8"	6 1/4"	10	25
6 1/2"	6 3/8"	10	25
6 5/8"	6 1/2"	10	25
6 3/4"	6 5/8"	10	25
6 7/8"	6 3/4"	10	Bulk
7"	6 7/8"	10	Bulk
7 1/8"	7"	10	Bulk
7 3/8"	7 1/8"	10	Bulk
7 1/2"	7 3/8"	10	Bulk
7 5/8"	7 1/2"	10	Bulk
3 7/8"	7 5/8"	10	Bulk
8"	7 7/8"	10	Bulk

## STRENGTHEN CHAIN TYPE PIPE CLAMPS

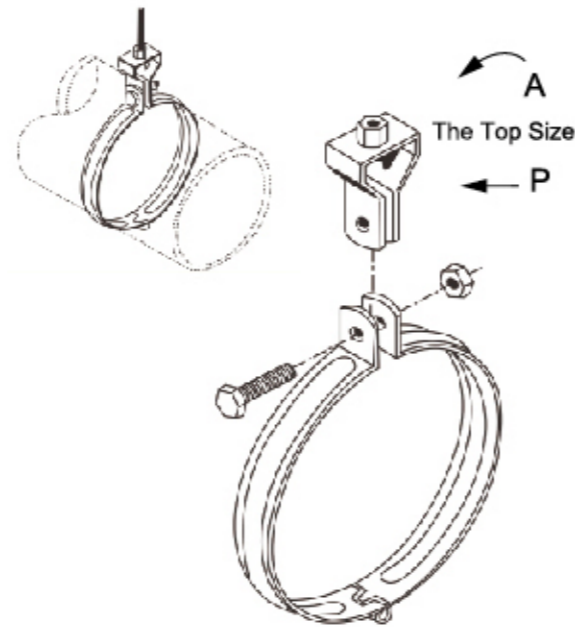

A	TxW	P	Allowable Load
M10,3/8	1.6×25	3/8"	2.9KN
M12,1/2	2.3×32	1/2"	5.4KN
M16,5/8	3.0×50	5/8"	12.7KN

Item No.	Pipe OD	TxW	Hex Screw	A Rod	Breaking Load
LXSA04	1/2"	1.6×25	M6×25	3/8",M110	4.9KN
LXSA06	3/4"	1.6×25	M6×25	3/8",M110	4.9KN
LXSA10	1"	1.6×25	M6×25	3/8",M110	4.9KN
LXSA12	1-1/4"	1.6×25	M6×25	3/8",M110	4.9KN
LXSA14	1-1/2"	1.6×25	M6×25	3/8",M110	4.9KN
LXSA20	2"	1.6×25	M6×25	3/8",M110	4.9KN
LXSA24	2-1/2"	2.3×25	M8×25	3/8",M110	6.1KN
LXSA30	3"	2.3×25	M8×25	3/8",M110	6.1KN
LXSA40	4"	2.3×25	M8×25	3/8",M110	6.1KN
LXSA50	5"	3.0×25	M10×40	1/2",M110	8.5KN
LXSA60	6"	3.0×25	M10×40	1/2",M110	8.5KN
LXSA80	8"	3.0×25	M12×50	1/2",M110	10.0KN
LXSA100	10"	4.0×25	M12×50	1/2",M110	13.0KN

## HEAVY DUTY PIPE CLAMPS

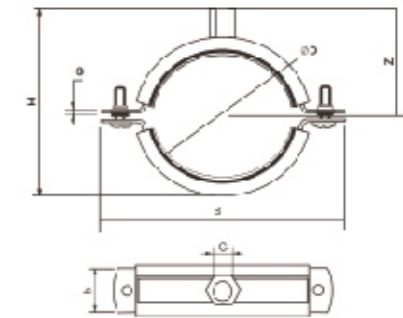

Item No.	Size	Pipe Size φD(mm)	Material BxS(mm)	Connection Height			Locking Screw	Rubber (mm)	Connection Height			Breaking Load N
				G	SW	H			B(mm)	H(mm)	Z(mm)	
LXHD012	1/4"	12-14	20X1.5	M8	13	12	M6X20	20X4.5	59	29	24	1200
LXHD015	3/8"	15-19	20X1.5	M8	13	12	M6X20	20X4.5	64	32	26	1200
LXHD021	1/2"	21-23	20X1.5	M8	13	12	M6X20	20X4.5	68	38	29	1200
LXHD026	3/4"	26-28	20X1.5	M8	13	12	M6X20	20X4.5	73	43	31	1200
LXHD032	1"	32-35	20X1.5	M8	13	12	M6X20	20X4.5	80	49	34	1200
LXHD040	1 1/4"	40-43	20X1.5	M8	13	12	M6X20	20X4.5	88	57	38	1200
LXHD044	1 1/2"	44-49	20X2.0	M8	13	12	M6X20	20X4.5	98	62	41	1200
LXHD050		50-56	20X2.0	M8/M10	13	17	M6X25	20X4.5	105	73	49	1500
LXHD057	2"	57-61	20X2.0	M8/M10	13	17	M6X25	20X4.5	110	80	52	1500
LXHD063		63-67	20X2.0	M8/M10	13	17	M6X25	20X4.5	116	86	55	1500
LXHD070		70-73	20X2.0	M8/M10	13	17	M6X25	20X7.5	122	93	59	1500
LXHD074	2 1/2"	74-80	20X2.0	M8/M10	13	17	M6X25	20X7.5	135	97	64	1500
LXHD083	3"	83-91	20X2.0	M8/M10	13	17	M6X25	20X7.5	146	106	68	1500
LXHD101		101-106	23X2.5	M8/M10	13	17	M6X25	23X7.5	165	126	78	2100
LXHD108	4"	108-114	23X2.5	M8/M10	17	18	M6X25	23X7.5	173	133	81	2500
LXHD125		125	23X2.5	M8/M10	17	18	M6X25	23X7.5	184	150	90	2500
LXHD131		131-135	23X2.5	M10	17	10	M6X25	23X7.5	194	154	91	2500
LXHD136		136-139	23X2.5	M10	17	10	M6X25	23X7.5	198	159	93	2500
LXHD140	5"	140-144	23X2.5	M10	17	10	M6X25	23X7.5	203	163	95	2500
LXHD159		159-163	23X2.5	M10	17	10	M6X25	23X7.5	222	182	105	2500
LXHD165	6"	165-169	23X2.5	M10	17	10	M6X25	23X7.5	228	188	108	2500
LXHD193		193-200	25X3.0	M10	17	10	M8X30	25X7.5	263	217	122	2800
LXHD210		210-212	25X3.0	M10	17	10	M8X30	25x7.5	275	234	131	2800
LXHD216	8"	216-220	25X3.0	M10	17	10	M8X30	25x7.5	283	240	134	2800
LXHD225		225	25X3.0	M10	17	10	M8X30	30x7.5	288	249	138	2800
LXHD250		250	25X3.0	M10	17	10	M8X30	30x7.5	313	274	151	2800
LXHD274	10"	274	25X3.0	M10	17	10	M8X30	30x7.5	337	298	163	2800
LXHD315		315	25X3.0	M10	17	10	M8X30	30x7.5	378	339	183	2800

## TPC PIPE CLAMPS

Two Pieces Clamp-TPC for Steel Pipe  
Finish: EG / Epoxy



Item No.	Pipe OD (mm)	WxT (mm)	L (mm)	Screw	Max.Rec. Load(N)
LXTP015	21.3	20X3.0	76	M8X25	1500
LXTP020	26.9	20X3.0	82	M8X25	1500
LXTP025	33.7	20X3.0	89	M8X25	1500
LXTP032	42.3	20X3.0	98	M8X25	1500
LXTP040	48.3	20X3.0	103	M8X25	1500
LXTP050	60.3	20X3.0	115	M8X25	1500
LXTP065	76.1	20X3.0	131	M8X25	1500
LXTP080	88.9	20X3.0	144	M8X25	1500
LXTP100	113.3	20X3.0	172	M8X25	2500
LXTP125	140	20X3.0	195	M8X25	4000
LXTP150	165.1	20X3.0	220	M8X25	4000

## CASTINGS PIPE CLAMPS

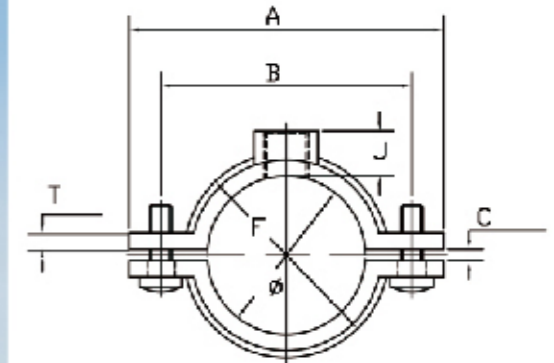

Item No.	A (mm)	B (mm)	C (mm)	T (mm)	J (mm)
LXSR018	49.5	35	1.3	2.5	6
LXSR020	54.75	41	1.9	3.25	7
LXSR028	63.6	50	1.5	3	8.2
LXSR034	67.6	54	2.5	3.5	9.7
LXSR042	81.7	68	2.5	3.8	9.5
LXSR050	87.7	72.3	2.5	3.8	9.4
LXSR060	99.5	83.5	2.5	3.5	9
LXSR075	123.7	103.5	5.5	4.5	13.5
LXSR090	145.6	126.4	5.5	6	14.8
LXSR120	176	154.2	8.5	7	16

## SINGLE HOLE PIPE CLAMPS

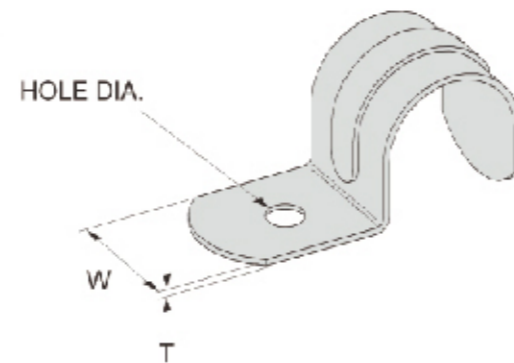

Item No.	Conduit Size		T		W		Hole Dia.		Wt./C	Lbs.Kg
LX2301-1/2	1/2"	(15)	0.5	(1.3)	3/4"	(19.0)	9/32"	(7.1)	2.4	(1.1)
LX2301-3/4	3/4"	(20)	0.5	(1.3)	7/8"	(22.2)	9/32"	(7.1)	4.2	(1.9)
LX2301-1	1"	(25)	0.5	(1.3)	1"	(25.4)	9/32"	(7.1)	8.3	(3.7)
LX2301-1 1/4	1 1/4"	(32)	0.65	(1.6)	1 1/4"	(31.7)	9/32"	(7.1)	11.0	(5.0)
LX2301-1 1/2	1 1/2"	(40)	0.90	(2.3)	1"	(25.4)	1 1/32"	(8.7)	14.8	(6.7)
LX2301-2	2"	(50)	0.90	(2.3)	1 1/4"	(31.7)	1 3/32"	(10.3)	21.6	(9.8)

## 2 HOLES PIPE CLAMPS

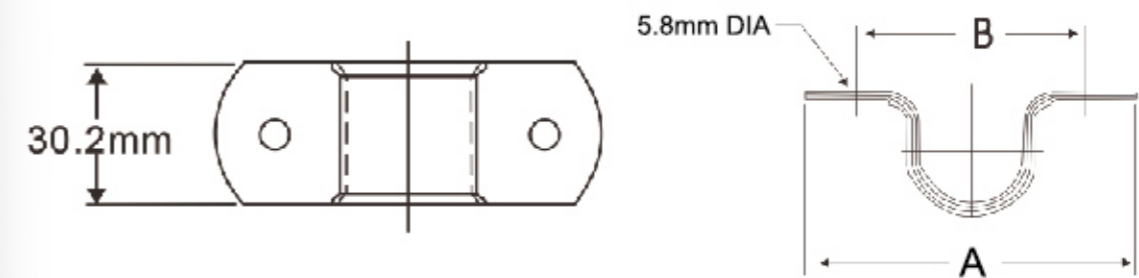

Item No.	Conduit Size	A (mm)	B (mm)	Max.Hanger Spacing(m)
LX10820	20(3/4")	82.6	57.2	1.7
LX10825	25(1")	88.9	63.5	1.8
LX10832	32(1-1/4")	108.0	82.6	2.0
LX10840	40(1-1/2")	112.7	87.3	2.1
LX10850	50(2")	125.4	100.0	2.4

### CPVC LX107

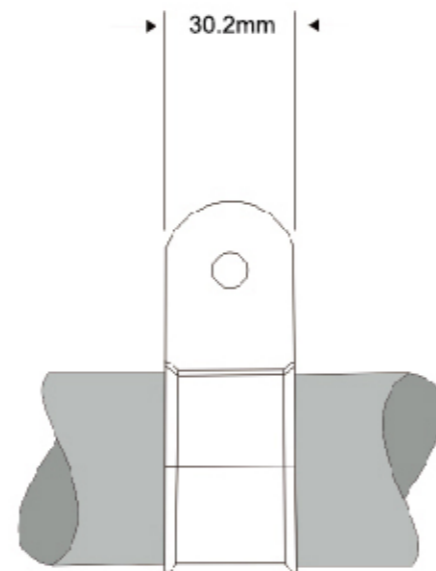
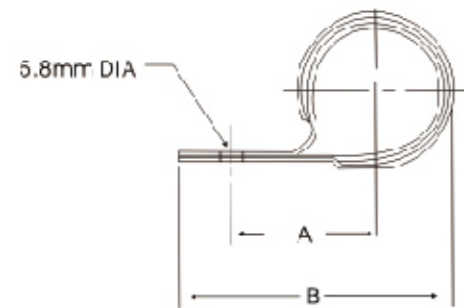
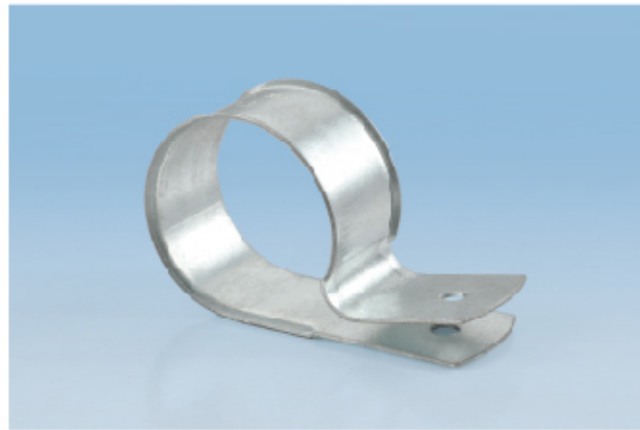

Item No.	Pipe Size (mm)	A (mm)	B (mm)	Max.Hanger Spacing(m)
LX10720	20(3/4")	31.8	60.3	1.7
LX10725	25(1")	36.5	68.3	1.8
LX10732	32(1-1/4")	41.3	77.8	2.0
LX10740	40(1-1/2")	44.5	84.1	2.1
LX10750	50(2")	47.6	93.7	2.4

### CPVC LX109

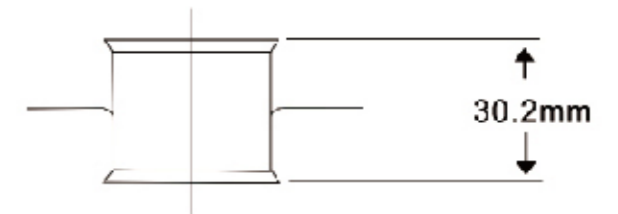
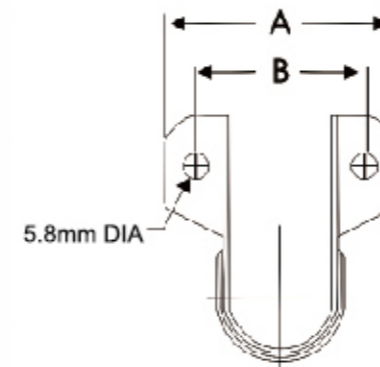

Item No.	Pipe Size (mm)	Pipe OD (mm)	A (mm)	B (mm)	Max.Hanger Spacing(m)
LX10920	20(3/4")	26.9	58.7	42.9	1.7
LX10925	25(1")	33.7	66.7	49.2	1.8
LX10932	32(1-1/4")	42.2	74.6	58.7	2.0
LX10940	40(1-1/2")	48.3	81.0	63.5	2.1
LX10950	50(2")	60.3	92.1	76.2	2.4

### CPVC SO

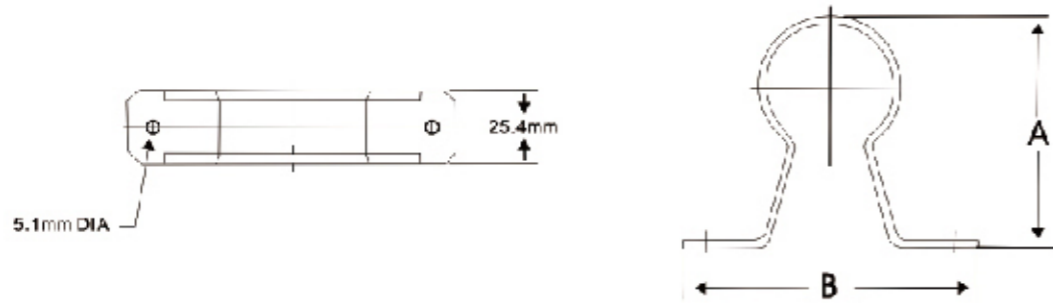

Item No.	Pipe Size (mm)	Pipe OD (mm)	A (mm)	B (mm)	Max.Hanger Spacing(m)
LX10020	20(3/4")	26.9	68.3	82.6	1.7
LX10025	25(1")	33.7	74.6	82.6	1.8
LX10032	32(1-1/4")	42.2	84.1	82.6	2.0
LX10040	40(1-1/2")	48.3	90.5	114.3	2.1
LX10050	50(2")	60.3	103.2	127.0	2.4

### LANTERN PIPE CLAMPS

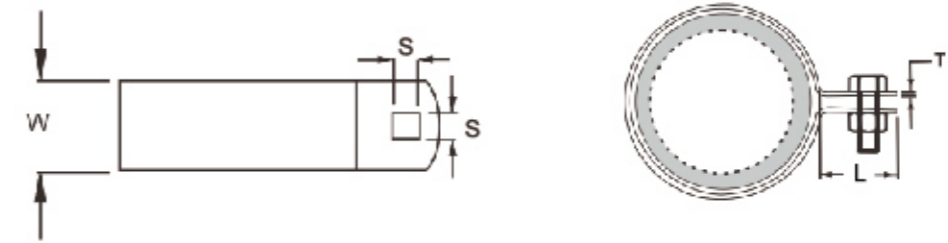

Item No.	Pipe Size (mm)	Pipe OD (mm)	WxT (mm)	L (mm)	S (mm)
LX-015	15	13	25x1.0	25	7x7
LX-020	20	19	25x1.0	25	7x7
LX-025	25	25	25x1.2	25	7x7
LX-032	32	32	25x1.2	25	7x7
LX-040	40	38	25x1.2	25	7x7
LX-050	50	51	25x1.4	25	7x7
LX-065	65	64	25x1.5	25	7x7
LX-080	80	76	25x1.5	25	7x7
LX-100	100	102	25x1.5	25	7x7
LX-125	200	127	25x1.7	25	7x7
LX-150	250	152	25x1.7	25	7x7

## PM TYPE HANGERS

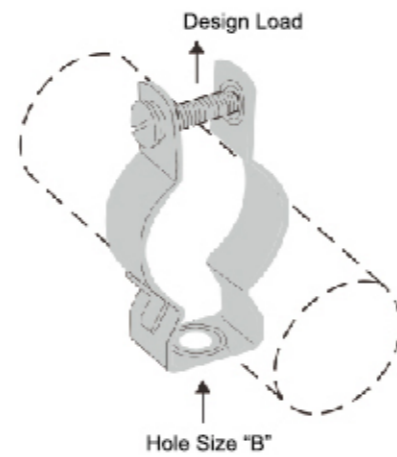

Item No.	Pipe Size (In)		Rod	Size of Steel (mm)	Bolt	Design Load (KN)
	Rigid Conduit	E.M.T.				
LXP015	1/2	1/2	M6	1.5×20	M8	2.6
LXP020	3/4	3/4	M6	1.5×20	M8	2.6
LXP025	1	1	M6	1.5×20	M8	2.6
LXP032T		1 1/4	M6	1.5×20	M8	2.6
LXP032	1 1/4	1 1/2	M8	1.5×20	M8	2.6
LXP040	1 1/2		M8	1.5×25	M10	3.4
LXP050	2	2	M8	1.5×30	M10	3.4
LXP065	2 1/2	2 1/2	M8	1.5×30	M10	3.4
LXP080	3	3	M8	1.5×30	M10	3.4
LXP090	3 1/2	3 1/2	M8	1.5×30	M10	3.4
LXP100	4	4	M8	1.5×30	M10	3.4

## RING HANGERS

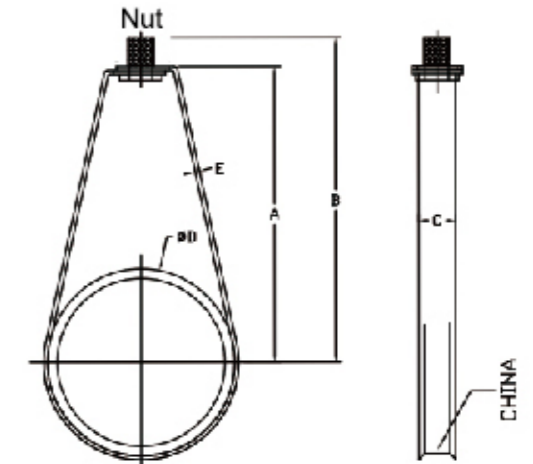
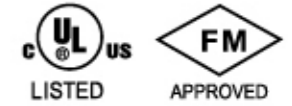

Item No.	Pipe Size (inch)	A(mm)	B(mm)	CxE(mm)	Nut	φ D(mm)
LXRH015	1/2	41.50	54.50	16X1.2	3/8	21.7
LXRH020	3/4	45.34	60.50	16X1.2	3/8	27.2
LXRH025	1	47.73	64.16	16X1.2	3/8	34.0
LXRH032	1-1/4	54.31	70.74	16X1.2	3/8	42.7
LXRH040	1-1/2	57.58	74.01	16X1.2	3/8	48.6
LXRH050	2	66.16	82.59	16X1.2	3/8	60.5
LXRH065	2-1/2	88.69	104.5	22X1.5	3/8	76.3
LXRH080	3	96.12	112.5	22X1.5	3/8	89.1
LXRH090	3-1/2	100.5	120.5	22X1.5	3/8	102
LXRH100	4	110.7	126.9	22X1.5	3/8	114
LXRH125	5	135.7	145.5	19X2	1/2	139.8
LXRH150	6	154.1	173.2	19X2	1/2	165.2
LXRH200	8	192.4	211.5	19X2.5	1/2	216.3

## J-TYPE HANGERS

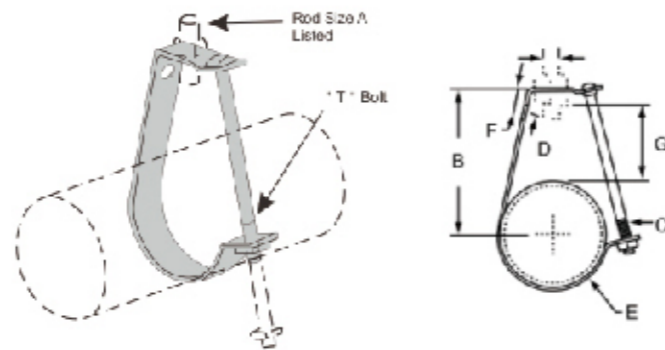

Item No.	Pipe Size (inch)	Pipe OD (mm)	Rod	Size of steel (mm)	D (mm)	Bolt	Design Load (KN)
LX-J-015	1/2	21.3	M10	3X20	11	M6X60	1.8
LX-J-020	3/4	26.7	M10	3X20	11	M6X65	1.8
LX-J-025	1	33.4	M10	3X20	11	M6X70	1.8
LX-J-032	1 1/4	42.2	M10	3X20	11	M6X75	1.8
LX-J-040	1 1/2	48.3	M10	3X20	11	M6X80	1.8
LX-J-050	2	60.3	M10	3X20	11	M6X90	1.8
LX-J-065	2 1/2	73.0	M12	3X30	14	M6X110	3.6
LX-J-080	3	88.9	M12	3X30	14	M6X130	3.6
LX-J-090	3 1/2	101.6	M12	3X30	14	M3X140	3.6
LX-J-100	4	114.3	M12	4X30	14	M6X160	3.6
LX-J-125	5	141.3	M12	4X30	14	M6X190	3.6
LX-J-150	6	168.3	M16	6X30	14	M6X220	4.5
LX-J-200	8	219.1	M16	6X40	14	M6X260	5.3

## CLEVIS HANGERS

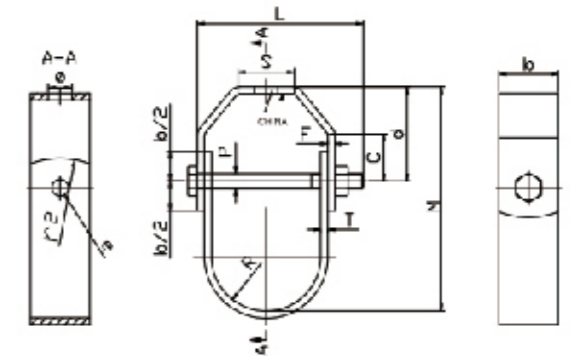

Item No.	Pipe Size (inch)	M	φ	d	r2	C	S	e	Bolt	Txb
LXCH020	3/4	82.5	11	46	40	20	24	φ 8	1/4X50	2.5X22.5
LXCH025	1	99	11	56.5	40	20	24	φ 8	1/4X57	2.5X22.5
LXCH032	1-1/4	106	11	54	40	23	24	φ 8	1/4X70	2.5X22.5
LXCH040	1-1/2	107	11	40	40	23	24	φ 8	1/4X75	2.5X22.5
LXCH050	2	126	11	56	40	21	25	φ 8	1/4X90	2.5X22.5
LXCH065	2-1/2	156	14	69	40	15	32	φ 11	3/8X110	3X26
LXCH080	3	169	14	53	40	15	32	φ 11	3/8X115	3X26
LXCH090	3-1/2	165	14	51	40	20	34	φ 11	3/8X140	4X30
LXCH100	4	200	17	72.5	40	20	45	φ 11	3/8X150	4X30
LXCH125	5	231	17	76	40	24	50	φ 14	1/2X200	4.5X32
LXCH150	6	260	20	77	40	21	50	φ 14	1/2X225	4.5X36.5
LXCH200	8	329	20	90	40	28	57	φ 17	5/8X280	4.5X42.5
LXCH250	10	381	23.7	84	80	30	54	φ 20	3/4X360	6X44.5
LXCH300	12	457	23.7	104.5	80	48	57	φ 20	3/4X410	6X50
LXCH350	14	514	27	123	80	38	94	φ 23.7	7/8X465	6X50
LXCH400	16	560	27	119	80	50	90	φ 27	1X520	6X64
LXCH450	18	638	32	135	80	50	105	φ 32	1-1/8X570	6.5X64
LXCH500	20	695	33.2	135	80	58	180	φ 33.2	1-1/4X645	8X76
LXCH600	24	803	33.2	155	80	58	215	φ 33.2	1-1/4X755	8X76

## RISER CLAMPS

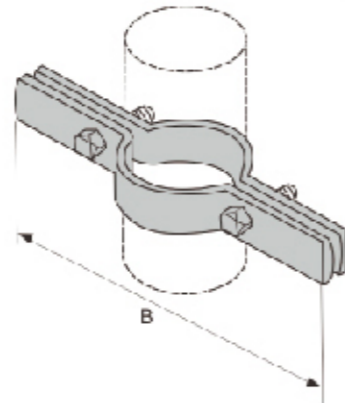
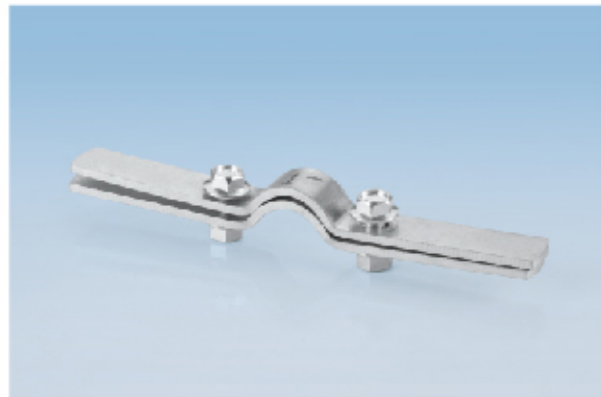

Item No.	Pipe Size (inch)	B (inch)	Bolt (inch)	Material Size (inch)	Max.Rec. Load/lbs	Wt.Each (inch)
LXRC015	1/2	9	3/8X1 1/4	7gax1-1/4	220	1.05
LXRC020	3/4	9 3/8	3/8X1 1/4	7gax1-1/4	220	1.05
LXRC025	1	9 5/8	3/8X1 1/4	7gax1-1/4	220	1.05
LXRC032	1 1/4	10	3/8X1 1/4	7gax1-1/4	250	1.10
LXRC040	1 1/2	10 3/8	3/8X1 1/4	7gax1-1/4	250	1.17
LXRC050	2	10 3/4	3/8X1 1/4	7gax1-1/4	300	1.20
LXRC065	2 1/2	11 1/4	3/8X1 1/2	3gax1-1/4	400	1.89
LXRC080	3	11 3/4	3/8X1 1/2	3gax1-1/4	500	1.99
LXRC090	3 1/2	13	3/8X1 1/2	3gax1-1/4	600	2.17
LXRC100	4	13 1/2	1/2X1 3/4	3gax1-1/4	750	2.21
LXRC125	5	14 1/2	1/2X1 3/4	3/8X1-1/2	1500	3.24
LXRC150	6	16	1/2X1 3/4	3/8X1-1/2	1600	3.89
LXRC200	8	18	5/8X2	3/8X1-1/2	2500	7.60
LXRC250	10	21 1/2	5/8X2	3/8X2	2500	11.10
LXRC300	12	23	5/8X1 1/2	1/2X2	2700	16.50
LXRC350	14	25	5/8X3	1/2X2	2700	17.70
LXRC400	16	26 1/4	3/4X3 1/2	5/8X2-1/2	2900	30.40
LXRC450	18	28 3/8	3/4X3 1/2	5/8X2-1/2	2900	33.30
LXRC500	20	30	3/4X3 1/2	5/8X2-1/2	2900	36.30
LXRC600	24	34 3/4	7/8X3 1/2	5/8X3	2900	48.68
LXRC750	30	40 3/4	7/8X3 1/2	5/8X3	2900	60.16

## ELECTRICAL CLAMPS

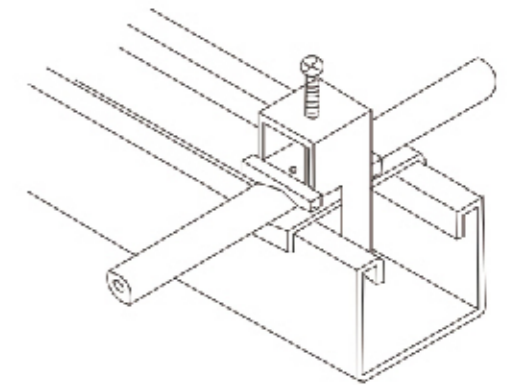
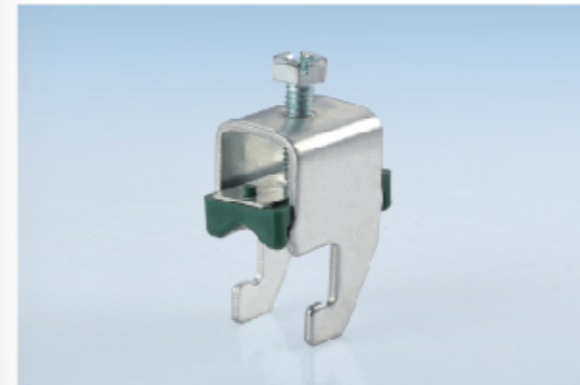

Sample

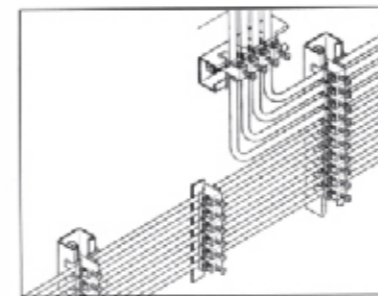

Load weight that allowed

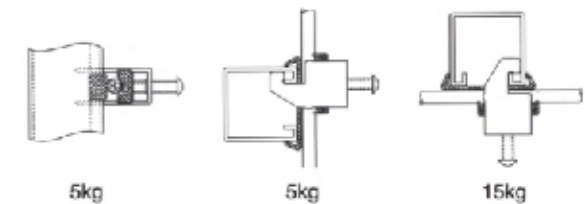

Item No.	Material	Pipe OD (mm)	Material thickness (mm)
TLXC-004	Carbon nickle	10-15	2
TLXC-005	Stainless steel	10-15	2

### BEAM CLAMPS

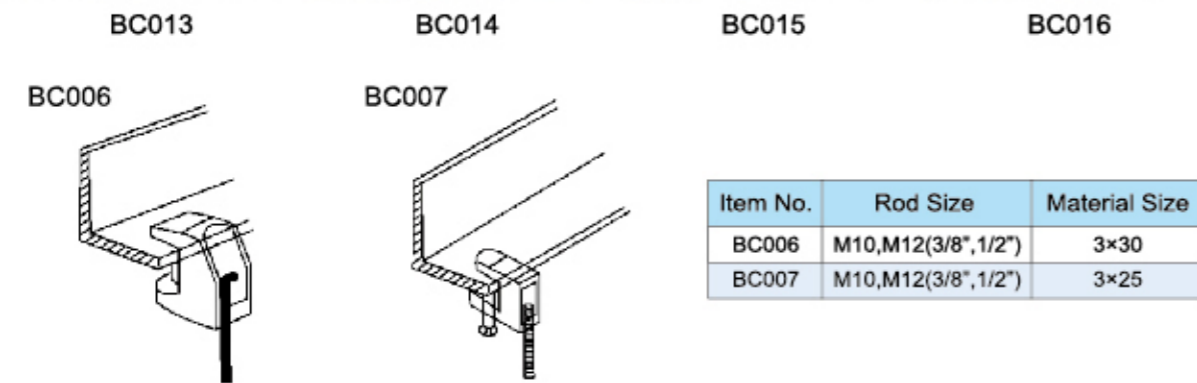

Maximum load weight 500kg      Maximum load weight 250kg

Item No.	Rod Size	Material Size
BC006	M10,M12(3/8",1/2")	3×30
BC007	M10,M12(3/8",1/2")	3×25

### BEAM CLAMPS

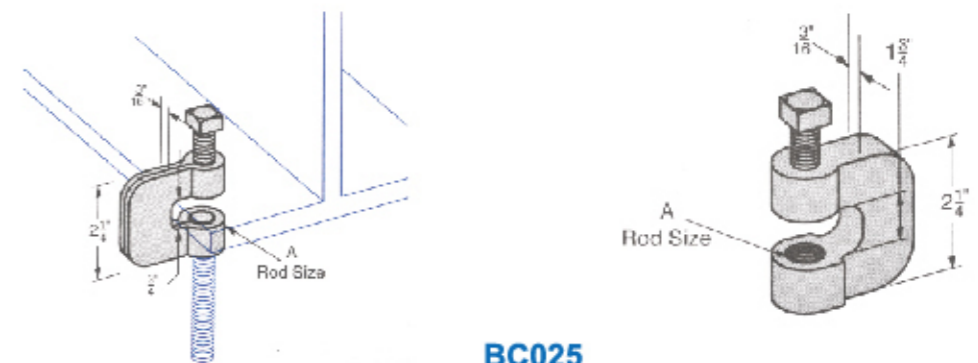

#### BC020

Item No.	A	Wt./100 Pcs.
BC020-3/8	3/8"	40
BC020-1/2	1/2"	40

#### BC025

Item No.	A	Wt./100 Pcs.
BC025-3/8	3/8"	32
BC025-1/2	1/2"	32

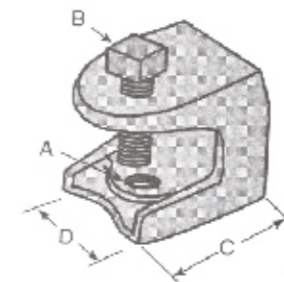

#### BC030

Item No.	Rod Size A	Set Screw B	C	D	Load Lbs.	Wt./100 Pcs.
BC030-1/4	1/4"	5/16"	1 3/8"	1 3/16"	150	24
BC030-5/16	5/16"	3/8"	1 3/8"	1 3/16"	150	24
BC030-3/8	3/8"	1/2"	1 7/8"	1 3/16"	350	65
BC030-1/2	1/2"	1/2"	2 3/8"	2 1/2"	1000	130

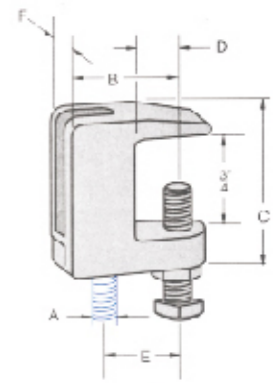

#### BC035

Item No.	Rod Size A	B	C	D	E	F	Max Load Lbs.	Wt./100 Pcs.
BC035-3/8	3/8"	1 1/2"	1 7/16"	3/4"	1 3/16"	3/4"	350	30
BC035-1/2	1/2"	1 5/8"	1 1/2"	3/4"	1 1/4"	7/8"	470	39
BC035-5/8	5/8"	1 1/2"	1 1/2"	3/4"	1 3/32"	1"	550	40
BC035-3/4	3/4"	1 3/4"	1 3/4"	1 1/16"	2 5/16"	1 1/4"	700	67

## ROLLERS & WHEEL TROLLEY

### Strut Pipe Roller LXROL001

Size Range:150nb to 400nb pipe.  
 Pipe rollers mount to strut for applications where there is longitudinal pipe movement  
 Hole Size:14mm  
 Width:41mm  
 Thickness:6mm  
 Finish:EG



### LXTWT001-Two Wheels Trolley

Material:Carbon Steel  
 wheels have stainless steel ball bearings  
 Load:300lbs  
 Finish:EG

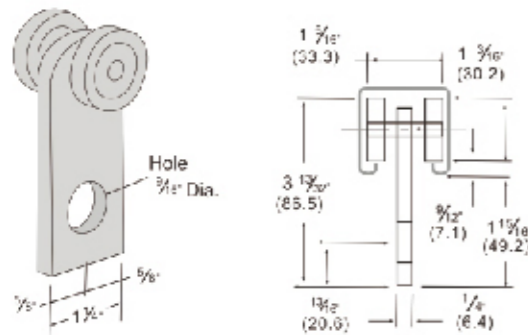
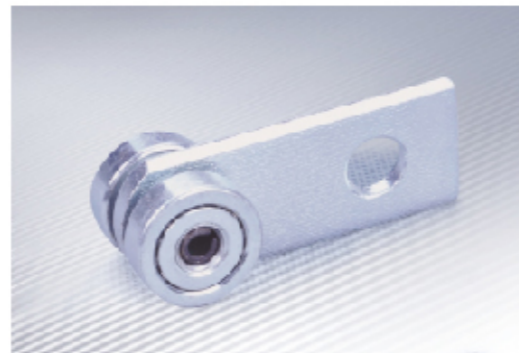

FPM	RPM	Design Load In PS 200 Lbs
180	600	150
90	300	225
30	100	437

### LXTWT002-Four Wheels Trolley

Material:Carbon Steel  
 wheels have stainless steel ball bearings  
 Load:600lbs  
 Finish:EG

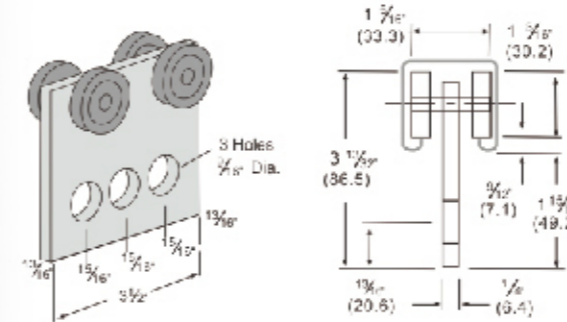
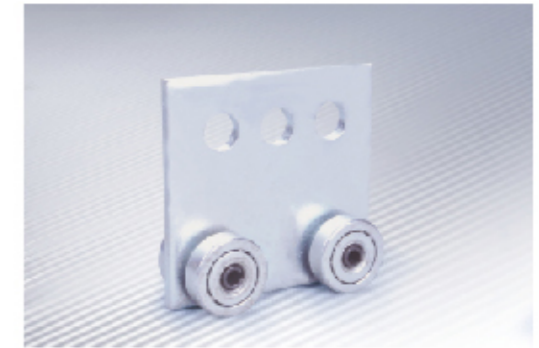

FPM	RPM	Design Load In PS 200 Lbs
180	600	300
90	300	450
30	100	600

### LXTWT003 Two Bearing Light Duty Trolley

Material:Carbon Steel  
 wheels have stainless steel ball bearings  
 Load:100lbs  
 Finish:EG

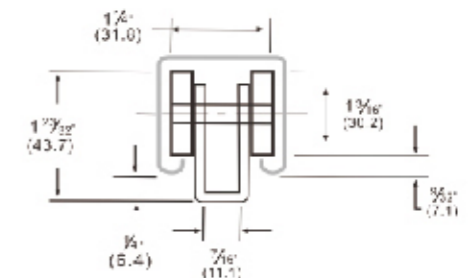
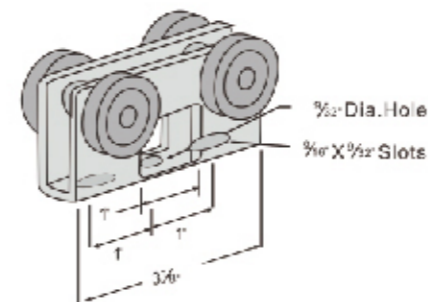
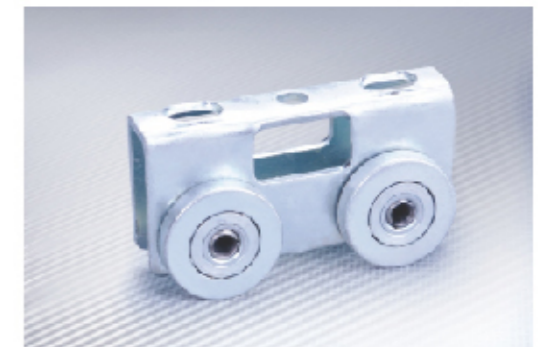

## SEISMIC BRACING

### Seismic Bracket

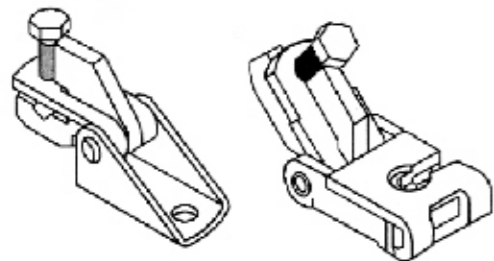

LXSB01

LXSB02

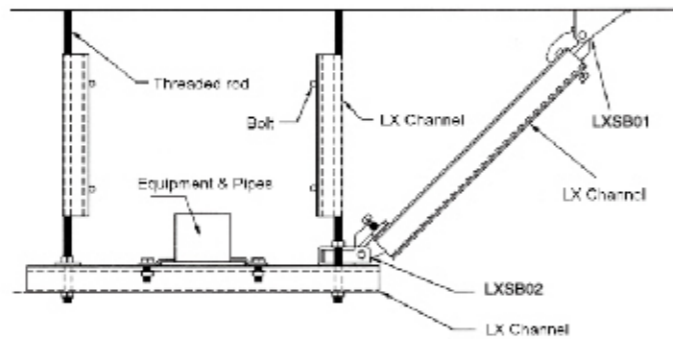

Diagram

### Bar Joist Attachment

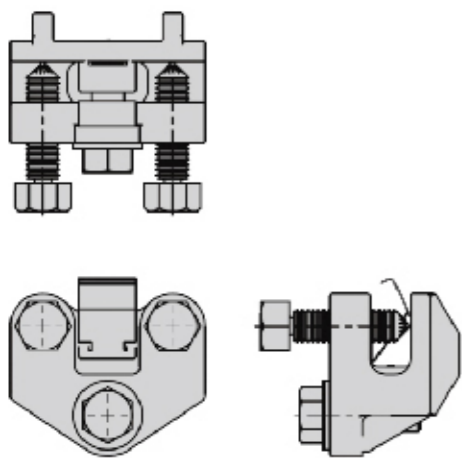

LXSB03

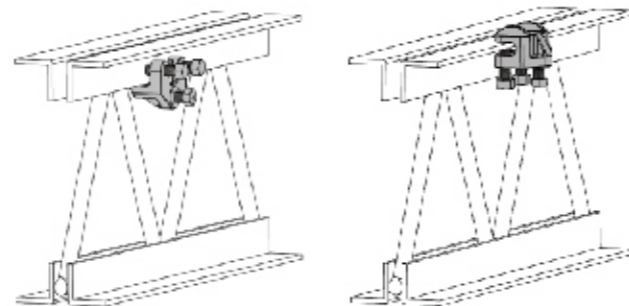

- 1.Can be installed on bar joist or I-beams
- 2.Thumb spring retainer allows for ease of positioning
- 3.Snap-off bolt head helps enable easy installation and inspection of seismic sway braces
- 4.No assembly required
- 5.No loose parts
- 6.Meets NFPA®-13 requirements for seismic sway bracing

### Adjustable I-Beam Attachment

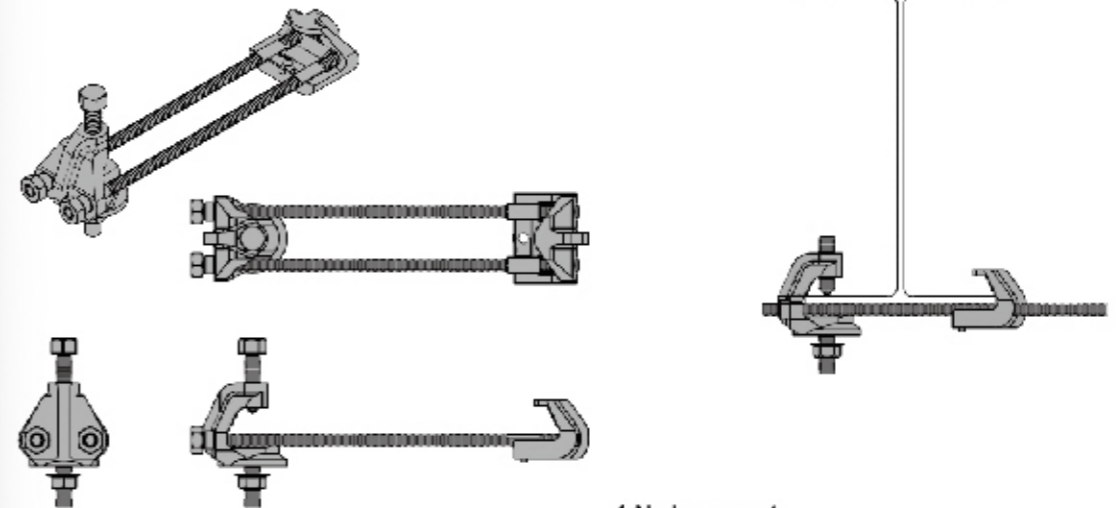

LXSB04

- 1.No loose parts
- 2.No assembly required
- 3.Snap-off bolt head helps enable easy installation and inspection of seismic sway braces
- 4.Meets NFPA®-13 requirements for seismic sway bracing

### Universal Structural Attachment

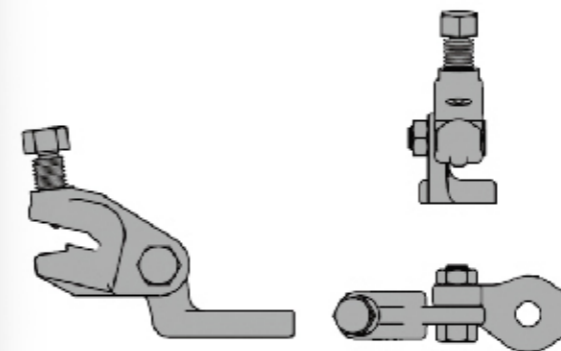

LXSB05

- 1.Universal design allows one product to attach directly to concrete ,wood,bar joist or I-beam adapters
- 2.Snap-off bolt head helps enable easy installation and inspection of seismic sway braces
- 3.Use for both lateral and longitudinal sway brace applications
- 4.Works with 1" through 2" brace pipes and 1/4" angle iron braces to reduce inventory
- 5.Center bolt does not require tightening
- 6.Meets NFPA®-13 requirements for seismic sway bracing

## SEISMIC BRACING

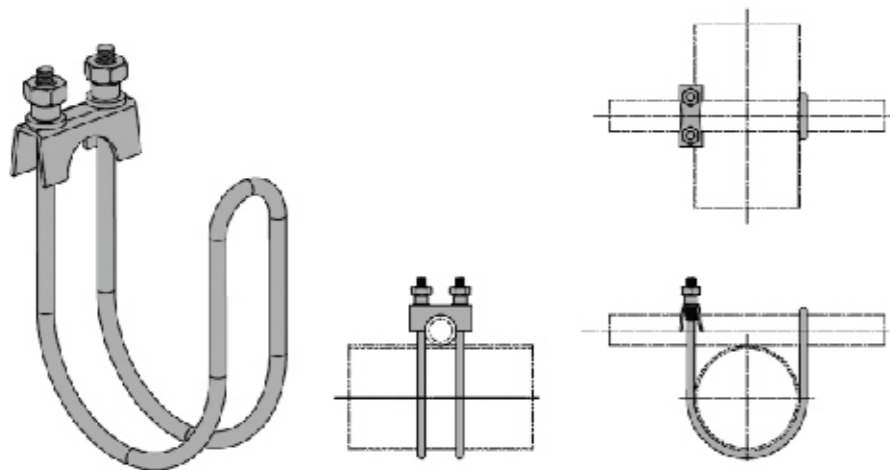

LXSB08

- 1.Quick and easy installation
- 2.Lower total installed cost
- 3.Meets requirements of NFPA®-13

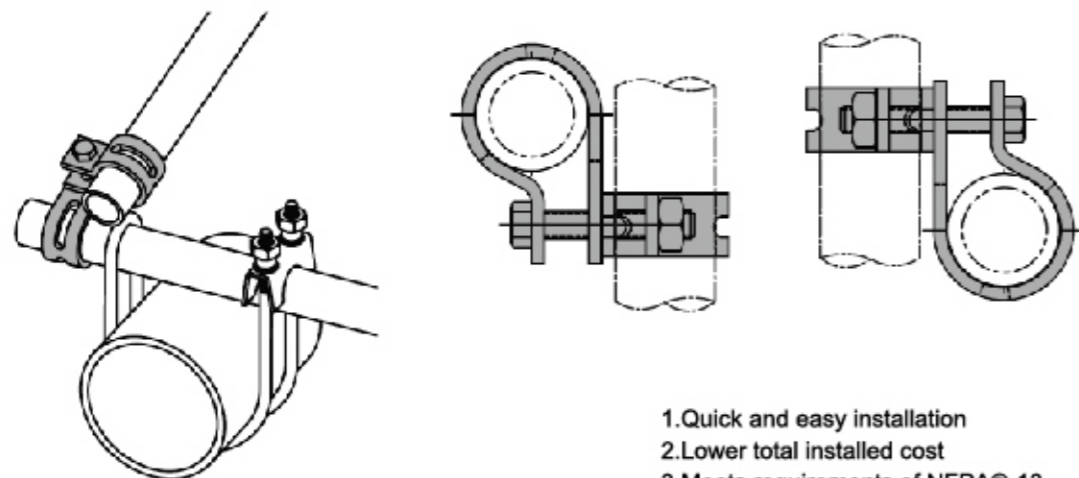

LXSB09

- 1.Quick and easy installation
- 2.Lower total installed cost
- 3.Meets requirements of NFPA®-13

## TECHNICAL DATA

1"Pipe Size - 1.313"O.D.					1-1/4"Pipe Size - 1.660"O.D.					1-1/2"Pipe Size - 1.900"O.D.				
Schedule No.	40	80	160		Schedule No.	40	80	160		Schedule No.	40	80	160	
Wall Designation	Std.	XS		XXS	Wall Designation	Std.	XS		XXS	Wall Designation	Std.	XS		XXS
Thickness - In.	0.133	0.179	0.250	0.358	Thickness - In.	0.140	0.191	0.25	0.382	Thickness - In.	0.145	0.200	0.281	0.400
Pipe - Lbs/Ft.	1.68	2.17	2.84	3.66	Pipe - Lbs/Ft.	2.27	3.00	3.76	5.22	Pipe - Lbs/Ft.	2.72	3.63	4.87	6.41
Water - Lbs/Ft.	0.37	0.31	0.23	0.12	Water - Lbs/Ft.	0.65	0.56	0.46	0.27	Water - Lbs/Ft.	0.88	0.77	0.61	0.41

2"Pipe Size - 2.375"O.D.					2-1/2"Pipe Size - 2.875"O.D.					3"Pipe Size - 3.500"O.D.				
Schedule No.	40	80	160		Schedule No.	40	80	160		Schedule No.	40	80	160	
Wall Designation	Std.	XS		XXS	Wall Designation	Std.	XS		XXS	Wall Designation	Std.	XS		XXS
Thickness - In.	0.154	0.218	0.343	0.436	Thickness - In.	0.203	0.276	0.375	0.552	Thickness - In.	0.216	0.300	0.438	0.600
Pipe - Lbs/Ft.	3.65	5.02	7.45	9.03	Pipe - Lbs/Ft.	5.79	7.66	10.0	13.7	Pipe - Lbs/Ft.	7.58	10.3	14.3	18.6
Water - Lbs/Ft.	1.46	1.28	0.97	0.77	Water - Lbs/Ft.	2.08	1.84	1.54	1.07	Water - Lbs/Ft.	3.2	2.86	2.34	1.80

3-1/2"Pipe Size - 4.000"O.D.					4"Pipe Size - 4.500"O.D.					5"Pipe Size - 5.563"O.D.					
Schedule No.	40	80			Schedule No.	40	80	120	160		Schedule No.	40	80	120	160
Wall Designation	Std.	XS		XXS	Wall Designation	Std.	XS		XXS	Wall Designation	Std.	XS		XXS	
Thickness - In.	0.266	0.318		0.636	Thickness - In.	0.237	0.337	0.437	0.531	0.674	Thickness - In.	0.258	0.375	0.500	0.625
Pipe - Lbs/Ft.	9.11	12.51		22.85	Pipe - Lbs/Ft.	10.8	15.0	19.0	22.5	27.5	Pipe - Lbs/Ft.	14.6	20.8	27.4	32.9
Water - Lbs/Ft.	4.28	3.85		2.53	Water - Lbs/Ft.	5.51	4.98	4.47	4.02	3.38	Water - Lbs/Ft.	8.66	7.89	7.06	7.33

6"Pipe Size - 6.625"O.D.						8"Pipe Size - 8.625"O.D.								
Schedule No.	40	80	120	160		Schedule No.	30	40	60	80	100	120	140	160
Wall Designation	Std.	XS			XXS	Wall Designation	Std.		XS					XXS
Thickness - In.	0.280	0.432	0.562	0.718	0.864	Thickness - In.	0.277	0.322	0.406	0.500	0.593	0.718	0.812	0.875
Pipe - Lbs/Ft.	19.0	28.6	36.4	45.3	53.2	Pipe - Lbs/Ft.	24.70	28.55	35.64	43.4	50.9	60.6	67.8	72.4
Water - Lbs/Ft.	12.5	11.3	10.3	9.16	8.14	Water - Lbs/Ft.	22.18	21.69	20.79	19.8	18.8	17.6	16.7	16.1

10"Pipe Size - 10.750"O.D.								12"Pipe Size - 12.750"O.D.									
Schedule No.	30	40	60	80	100	120	140	160	Schedule No.	30	40	60	80	100	120	140	160
Wall Designation		Std.	XS						Wall Designation		Std.		XS				
Thickness - In.	0.307	0.365	0.500	0.593	0.718	0.843	1.000	1.125	Thickness - In.	0.330	0.375	0.406	0.500	0.687	0.843	1.000	1.125
Pipe - Lbs/Ft.	34.24	40.5	54.7	64.3	76.9	89.2	104.1	115.7	Pipe - Lbs/Ft.	43.8	49.6	53.5	65.4	88.5	107.2	125.5	139.7
Water - Lbs/Ft.	34.98	34.1	32.3	31.1	29.5	28	26.1	24.6	Water - Lbs/Ft.	49.7	49.0	48.5	47.0	44.0	41.6	39.3	37.5

14"Pipe Size - 14.0"O.D.								16"Pipe Size - 16.0"O.D.									
Schedule No.	20	30	40	80	100	120	140	160	Schedule No.	20	30	40	80	100	120	140	160
Wall Designation		Std.		XS					Wall Designation		Std.		XS				
Thickness - In.	0.312	0.375	0.437	0.500	0.750	0.937	1.093	1.250	Thickness - In.	0.312	0.375	0.500	0.843	1.031	1.218	1.437	1.593
Pipe - Lbs/Ft.	45.7	54.6	63.4	72.1	106.1	130.7	150.7	170.2	Pipe - Lbs/Ft.	52.4	62.6	82.8	136.5	164.8	192.3	223.6	245.1
Water - Lbs/Ft.	60.92	59.7	58.7	57.5	53.2	50.0	47.5	45.0	Water - Lbs/Ft.	80.5	79.1	76.5	69.7	66.1	62.6	58.6	55.9

18"Pipe Size - 18.0"O.D.								20"Pipe Size - 20.0"O.D.									
Schedule No.	20	30	40	60	80	120	160	Schedule No.	20	30	40	60	80	100	120	140	160
Wall Designation		Std.		XS				Wall Designation		Std.	XS						
Thickness - In.	0.312	0.375	0.437	0.500	0.563	0.750	0.937	Thickness - In.	0.375	0.500	0.593	0.812	1.031	1.281	1.500	1.750	
Pipe - Lbs/Ft.	59.0	70.6	82.1	93.5	104.8	138.2	170.8	Pipe - Lbs/Ft.	78.6	104.1	122.9	166.4	208.9	256.1	296.4	341.1	
Water - Lbs/Ft.	102.8	101.2	99.9	98.4	97.0	92.7	88.5	Water - Lbs/Ft.	126.0	122.8	120.4	115.0	109.4	103.4	98.3	92.6	

20"Pipe Size - 20.0"O.D.								
Schedule No.	20	40	60	80	100	120	140	160
Wall Designation	Std.	XS						
Thickness - In.	0.375	0.500	0.687	0.968	1.218	1.531	1.822	2.062
Pipe - Lbs/Ft.	94.6	125.5	171.2	238.1	296.4	367.4	429	484
Water - Lbs/Ft.	183.8	180.1	174.3	165.8	158.3	149.3	141	134

## TECHNICAL DATA

Threaded Rod Load Rating			
Nominal Rod Diameter, In.	Root Area Thread, In.	Maximum Safe Load, Lbs Rod Temperatures	
		650°F	750°F
3/8"	0.068	610	540
1/2"	0.128	1,130	1,010
5/8"	0.202	1,810	1,610
3/4"	0.302	2,710	2,420
7/8"	0.419	3,770	3,360
1"	0.552	4,960	4,420
1 1/8"	0.693	6,230	5,560
1 1/4"	0.889	8,000	7,140
1 1/2"	1.293	11,630	10,370
1 3/4"	1.744	15,700	14,000
2"	2.300	20,700	18,460

Rod Size as Determined by Pipe Size	
Pipe Size	Rod Size
3/4" to 2" Inclusive	3/8"
2-1/2" to 3-1/2"	1/2"
4" and 5"	5/8"
6"	3/4"
8" to 12" Inclusive	7/8"

Water Filled Pipe Weights For Pipe Hangers Loated On 6 Ft Centers At 1/4 Span From Each End											
Size	2"	2-1/2"	3"	4"	5"	6"	8"	10"	12"		
Sch 40 Pipe Weight Per Ft (Lbs)	3.65	5.79	7.57	10.78	14.60	18.95	28.52	40.44	53.47		
Water Weight Per Ft (Lbs)	1.45	2.07	3.20	5.51	8.67	12.52	21.67	34.16	48.49		
Total Weight Per Ft (Lbs)	5.10	7.86	10.77	16.29	23.27	31.47	50.20	74.60	101.96		
Pipe Hanger Centers (Ft)	6	6	6	6	6	6	6	6	6		
Total Weight Per 6 Ft Center - One Pipes (Lbs)	31	47	65	98	140	189	301	448	612		
Total Weight Per 6 Ft Center - Two Pipes (Lbs)	61	94	129	196	279	378	602	895	1,223		
Recommended 3 Ft Span Pipe Hanger Top Beam	H-132	H-132	H-132	H-132	H-132	H-132	H-122	H-112	H-112		
Recommended 4 Ft Span Pipe Hanger Top Beam	H-132	H-132	H-132	H-132	H-132	H-122	H-112	H-112	H-122A		
Recommended 5 Ft Span Pipe Hanger Top Beam	H-132	H-132	H-132	H-132	H-122	H-122	H-112	H-122A	H-122A		
Recommended 6 Ft Span Pipe Hanger Top Beam	H-132	H-132	H-132	H-132	H-122	H-122	H-112	H-122A	H-122A		

Water Filled Pipe Weights For Pipe Hangers Loated On 8 Ft Centers At 1/4 Span From Each End											
Size	2"	2-1/2"	3"	4"	5"	6"	8"	10"	12"		
Sch 40 Pipe Weight Per Ft (Lbs)	3.65	5.79	7.57	10.78	14.60	18.95	28.52	40.44	53.47		
Water Weight Per Ft (Lbs)	1.45	2.07	3.20	5.51	8.67	12.52	21.67	34.16	48.49		
Total Weight Per Ft (Lbs)	5.10	7.86	10.77	16.29	23.27	31.47	50.20	74.60	101.96		
Pipe Hanger Centers (Ft)	8	8	8	8	8	8	8	8	8		
Total Weight Per 8 Ft Center - One Pipes (Lbs)	41	63	86	130	186	252	402	597	816		
Total Weight Per 8 Ft Center - Two Pipes (Lbs)	82	126	172	261	372	504	803	1,194	1,631		
Recommended 3 Ft Span Pipe Hanger Top Beam	H-132	H-132	H-132	H-132	H-132	H-122	H-112	H-112	H-112A		
Recommended 4 Ft Span Pipe Hanger Top Beam	H-132	H-132	H-132	H-132	H-132	H-122	H-112	H-112	H-122A		
Recommended 5 Ft Span Pipe Hanger Top Beam	H-132	H-132	H-132	H-122	H-122	H-112	H-122A	H-122A	H-112A		
Recommended 6 Ft Span Pipe Hanger Top Beam	H-132	H-132	H-132	H-122	H-122	H-112	H-122A	H-112A	H-112A		

## MAXIMUM SPACING BETWEEN SUPPORTS

Nominal Tube Size, In	1/2"	3/4"	1"	1-1/2"	2"	2-1/2"	3"	3-1/2"	4"
Maximum Span, Ft.	5	6	6	8	9	10	10	11	12

Nominal Tube Size, In	1/2"	3/4"	1"	1-1/2"	2"	2-1/2"	3"	3-1/2"	4"	5"	6"	8"	10"	12"	14"	16"	18"	20"	24"
Maximum Water Span, Ft.	5	6	7	9	10	11	12	13	14	16	17	19	22	23	25	27	28	30	32
Span, Ft. Air & Steam	-	-	9	11	13	14	15	16	17	19	21	24	28	30	32	35	37	39	42

	NO.	Thickness	Height	Width	Length	C	D	Weight	Attention
Hight Foot LX41	H2500	2.5mm	41mm	41mm	3M	22mm	7mm	2.77kg/M	
	H2500	2.0mm	41mm	41mm	3M	22mm	7mm	2.22kg/M	
Low Foot LX21	H2000L	2.0mm	25mm	41mm	3M	22mm	7mm	1.76kg/M	
	H2000L	2.0mm	2.6mm	41.3mm	3M	22mm	7mm	1.53kg/M	
	H1600L	1.6mm	25mm	41mm	3M	22mm	7mm	1.44kg/M	
Stengthen	H1600L	1.6mm	21.3mm	41.3mm	3M	22mm	7mm	1.35kg/M	
	H2500L	2.5mm	62mm	41mm	3M	22mm	7mm	3.60kg/M	
Special	HL2500	2.5mm	41mm	41mm	3M	22mm	7mm	2.66kg/M	
	HL2000	2.0mm	41mm	41mm	3M	22mm	7mm	2.09kg/M	
	H2510	2.5mm	41mm	41mm	20CM-3M	22mm	7mm	2.92kg/M	Use for inserting
Stainless	H2000S	2.0mm	41mm	41mm	3M	22mm	7mm	2.29kg/M	
	H1500S	1.5mm	41mm	41mm	3M	22mm	7mm	1.75kg/M	
	H200LS	2.0mm	25mm	41mm	3M	22mm	7mm	1.78kg/M	
	H1500LS	1.5mm	25mm	41mm	3M	22mm	7mm	1.37kg/M	

No.	Dimensions of transverse section mm²	axes1-1			axes2-2		
		Distances of inertia cm	Distances of resisting beding cm	Distances of inertia cm	Distances of inertia cm	Distances of resisting beding cm	Distances of inertia cm²
H2500	352.5	7.93	3.53	1.50	9.67	4.72	1.66
H2500	288	6.67	2.98	1.52	8.04	3.92	1.67
H2000L	224	1.98	1.41	0.94	5.61	2.73	1.58
H1600L	183.1	1.67	1.2	0.96	4.65	2.27	1.59
H2500L	457.5	22.32	6.7	2.21	13.56	6.62	1.72
H2000S	288	6.67	2.98	1.52	8.04	3.92	1.67
H1500S	22.05	5.26	2.36	1.54	6.27	3.06	1.69
HL2000LS	224	1.98	1.41	0.94	5.61	2.72	1.58
HL1500LS	172.5	1.59	1.14	0.96	4.39	2.14	1.60

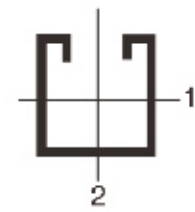





## TECHNICAL DATA

Distance between simple horizontal stands	NO.	Uniform load at 140Mpa	Deflection at 140Mpa Stress	Uniform load at max derlection=1/240
60	H2500	6.50	1.15	-
60	H2000	5.49	1.16	-
60	H2000	2.60	1.85	-
60	H1600L	2.21	1.86	-
60	H2500H	2.35	0.78	-
60	H2000S	4.91	1.04	-
60	H5000S	3.89	1.65	-
60	H2000LS	2.32	1.65	-
60	H1500LS	1.88	1.66	-
75	H2500	5.20	1.80	-
75	H2000	4.40	1.81	-
75	H2000L	2.88	2.80	-
75	H1600L	1.96	2.90	-
75	H2500H	9.88	1.22	-
75	H2000S	3.93	1.62	-
75	1500S	3.11	1.63	-
75	H2000LS	1.86	2.58	-
75	H1500LS	1.50	2.59	-
90	H2500	4.33	2.59	-
90	H2000	3.66	2.61	-
90	H2000L	1.73	4.15	1.56
90	H1600L	1.47	4.17	1.32
90	H2500L	8.23	1.75	-
90	H2000S	3.27	2.33	-
90	H1500S	2.59	2.34	-
90	H2000LS	1.55	3.71	-
90	H1500LS	1.25	3.74	-

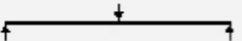
Distance between simple horizontal stands	NO.	Uniform load at 140Mpa	Deflection at 140Mpa Stress	Uniform load at max derlection=1/240
120	H2500	3.25	4.61	-
120	H2000	2.75	4.64	-
120	H2000L	1.30	7.39	0.88
120	H1600L	1.10	7.42	0.74
120	H2500H	6.18	3.12	-
120	H2000S	2.46	4.14	-
120	H5000S	1.95	4.17	-
120	H2000LS	1.16	6.60	0.88
120	H1500LS	0.94	6.64	0.71
150	H2500	2.60	7.20	0.25
150	H2000	2.20	7.15	1.90
150	H2000L	1.04	11.54	0.56
150	H1600L	0.88	11.6	0.48
150	H2500H	4.82	4.95	-
150	H2000S	1.96	6.47	1.90
150	H1500S	1.56	6.51	1.49
150	H2000LS	0.93	10.31	0.56
150	H1500LS	0.75	10.83	0.45
180	H2500	2.17	10.37	1.57
180	H2000	1.83	10.42	1.23
180	H2000L	0.87	16.62	0.39
180	H1600	0.74	16.70	0.33
180	H2500L	4.01	7.12	-
180	H2000S	1.64	9.32	1.37
180	H1500S	1.30	9.38	1.04
180	H2000LS	0.77	14.85	0.39
180	H1500LS	0.63	14.94	0.31

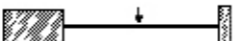
## TECHNICAL DATA

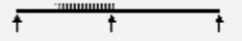
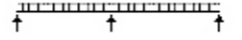
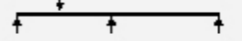
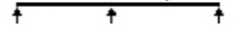
Load and support		Load elements	Deflection at stress elements
Simple bracket	Load in average 	1.00	1.00
Simple bracket	Load in center concentrate 	0.50	0.80
Simple bracket	Load in two equal concentrates 	1.00	1.00
Bracket fixed on two ends	Load in average 	1.50	0.30
Bracket fixed on two ends	Load in center concentrate 	1.00	0.40
Handing bracket	Load in average 	0.25	2.40
Handing bracket	Load in the other side concentrate 	0.12	3.20
Continual bracket	Load in average in one side 	1.30	0.92
Continual bracket	Load in average 	1.00	0.42
Continual bracket	Load in one concentrate 	0.62	0.71
Contional bracket	Load in two equal concentrates 	0.67	0.48

### Simple example

Load in center concentrate of simple bracket. Decide so choose H2500 channel to conclude the load elements and deflection at stress elements.



### Instruction

1. Check load exchange data, the distance between two point of H2500 is 750mm, Load elements is 5.2KN, deflection is 1.8mm
2. Reference above table, Load = 5.2KN \* 0.5 = 2.6KN
3. Derlection = 1.8mm \* 0.8 = 1.44mm

## TESTING REPORT

Zhejiang Lianxiang Hardware Science and Technology Co.,Ltd

### MATERIAL TESTING REPORT

- |                                                                            |                                                    |
|----------------------------------------------------------------------------|----------------------------------------------------|
| 1、 Company Name:Zhejiang Lianxiang Hardware Science and Technology Co.,Ltd | 10、 Name:LX-41-2.5                                 |
| 2、 Operator:Zhou Chunyan                                                   | 11、 Distance:100.00mm                              |
| 3、 Date No:C2168                                                           | 12、 Cross section:Irregular                        |
| 4、 Date:Dec.18,2015                                                        | 13、 Area:216.8mm <sup>2</sup>                      |
| 5、 Time: AM 10:50:38                                                       | 14、 Energy:5391Kgf.mm                              |
| 6、 Temperature:24.3 C                                                      | 15、 Figures of Yang : Infkgf/mm <sup>2</sup>       |
| 7、 Speed:10.00mm/min                                                       | 16、 Notice                                         |
| 8、 Type:Pull Out Experiment                                                | 17、 Name of the file: H:\pull out report\C channel |
| 9、 Standard: C Channel                                                     |                                                    |

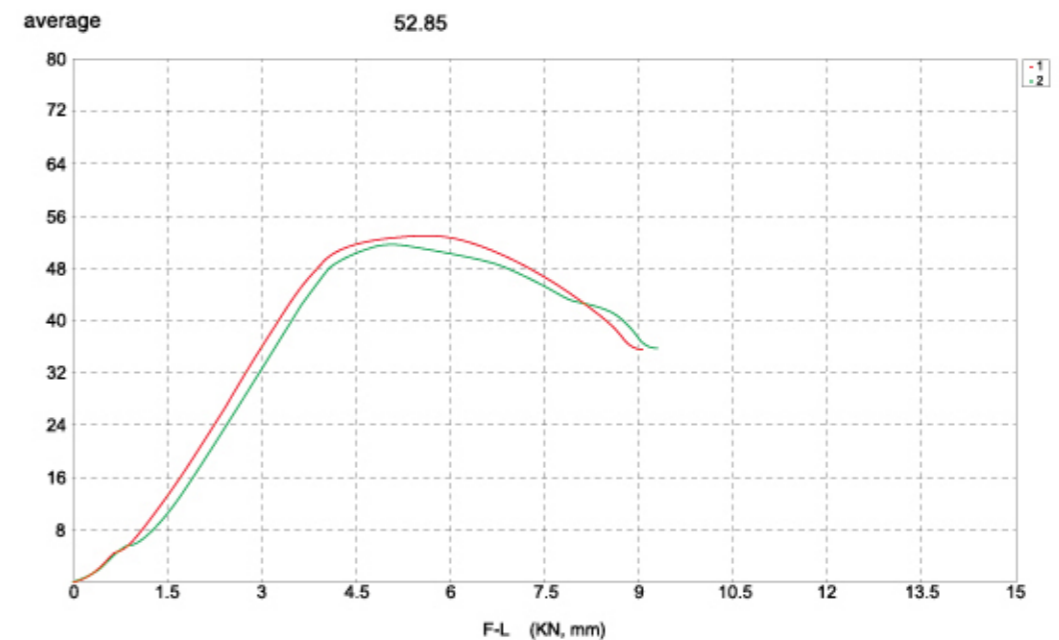

## TESTING REPORT

Zhejiang Lianxiang Hardware Science and Technology Co.,Ltd

### MATERIAL TESTING REPORT

- |                                                                            |                                                       |
|----------------------------------------------------------------------------|-------------------------------------------------------|
| 1、 Company Name:Zhejiang Lianxiang Hardware Science and Technology Co.,Ltd | 10、 Name:LX-41-2.0                                    |
| 2、 Operator:Zhou Chunyan                                                   | 11、 Distance:25.00mm                                  |
| 3、 Date No:C2118                                                           | 12、 Cross section:Irregular                           |
| 4、 Date:Jan.15,2015                                                        | 13、 Area:314mm <sup>2</sup>                           |
| 5、 Time: AM 11:16:28                                                       | 14、 Energy:8340Kgf.mm                                 |
| 6、 Temperature:25.5℃                                                       | 15、 Figures of Yang : Infkgf/mm <sup>2</sup>          |
| 7、 Speed:10.00mm/min                                                       | 16、 Notice                                            |
| 8、 Type:Pull out experiment                                                | 17、 Name of the file: H:\pulling out report\C channel |
| 9、 Standard: Inserted channel                                              |                                                       |

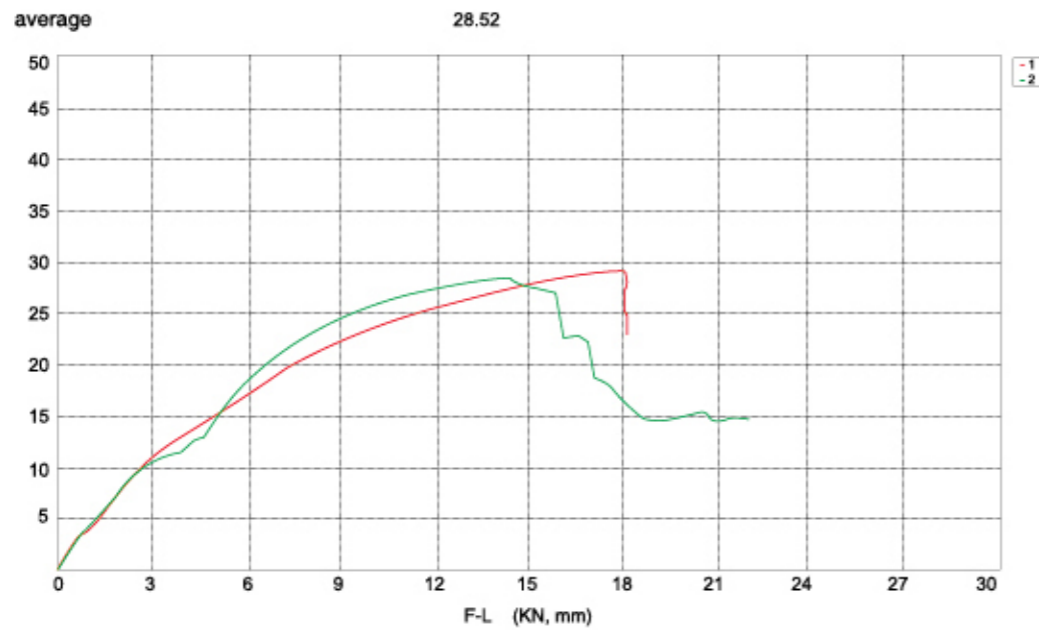

## PROJECT CASE

